

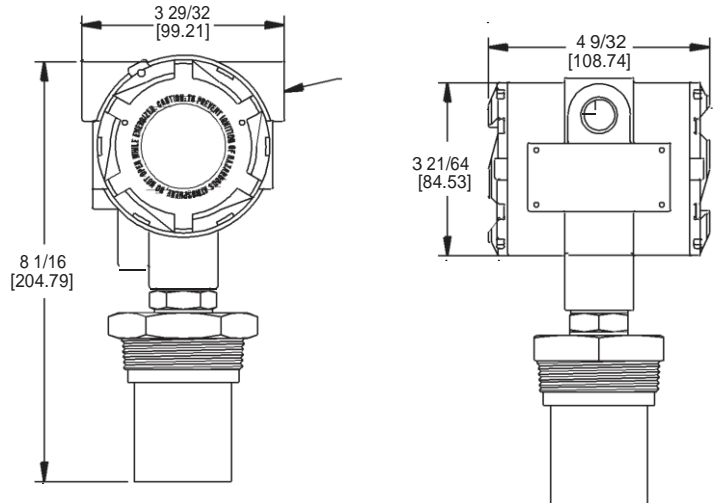

# THE BULLET OPERATION MANUAL



The **ECHO BULLET - Ultrasonic Level Transmitter** provides reliable, accurate, noncontact measurement of liquid levels. Ultrasonic non-contact technology offers no moving parts to wear, jam, corrode, or get coated like contact technologies. Mapping software makes effective measuring surface only a 3" diameter column. No concerns with ladders, pipes, or other tank intrusions in the remaining sound cone. Unit is FM approved explosion-proof making it ideal for use in hazardous locations. The BULLET features easy programming with 6 digit LCD display and simple menu structure. Output range is adjustable with choices of inputting tank dimensions or just fill and empty the tank while calibrating and it automatically scales to levels it senses. Window cover allows early viewing of display. Failsafe output options and diagnostic capabilities makes the BULLET a good choice for critical applications.

#### Models:

*The come standard with 2" MNPT and ½" FNPT conduit.  
Optional 2" BSPT Male with M20 conduit is available.*

**The Bullet – 7m      Range: 0 – 23' (7m)**

**The Bullet – 10m      Range: 0 – 33' (10m)**

PLEASE CALL US FOR ANY QUESTIONS:

ECHO Process Instrumentation, Inc.  
70 6<sup>th</sup> Ave, Shalimar, FL 32579 USA  
Phone: 850.609.1300 Fax: 850.651.4777  
Email: [info@echopi.com](mailto:info@echopi.com)  
Website: [www.echopi.com](http://www.echopi.com)

#### SPECIFICATIONS

**Service:** Compatible fluids. Not for use with powder and bulk solids.  
**Wetted Materials:** Sensor: PVDF; process connection: 303 SS.  
**Ranges:** 23' (7 m), 32.8' (10 m).  
**Accuracy:** ±0.2% of maximum range.  
**Resolution:** 0.079" (2 mm).  
**Blind Zone:** Under 8" (20 cm).  
**Beam Width:** 3" (7.6 cm) diameter.  
**Temperature Limits:** Ambient: -40 to 140°F (-40 to 60°C),  
 Process: -4 to 140°F (-20 to 60°C).  
**Temperature Compensation:** -40 to 140°F (-40 to 60°C)  
**Pressure Limits:** 30 psi (2 bar) up to 25°C (77°C). Above 25°C (77°F), rating decreases 1.667 psi per 1°C increase. See chart. See pressure and temperature chart.  
**Power Requirement:** 18 to 28 VDC (2 wire).  
**Output Signal:** 4 to 20 mA or 20 to 4 mA (Two-wire).  
**Max. Loop Resistance:** 250 Ohms at 24 VDC.  
**Electrical Connections:** Screw terminal.  
**Conduit Connection:** 1/2" NPT female (two) or M20.  
**Process Connection:** 2" NPT male or BSPT.  
**Enclosure Rating:** Weather-proof meets NEMA 4X, explosion-proof rated Class I, Div. 1, Groups B, C, D; Class II/III, Div. 1, Groups E, F, G.  
**Failsafe:** On lost echo after 30 seconds, user selectable to 4, 20, 21, 22 mA or last signal.  
**Memory:** Non-volatile.  
**Display:** 6 character LCD.  
**Units:** In, cm, ft, m, percent.  
**Memory:** Non-volatile.  
**Programming:** 4 button.  
**Weight:** 4.0 lb (1.8 kg)  
**Agency Approvals:** CE, FM.

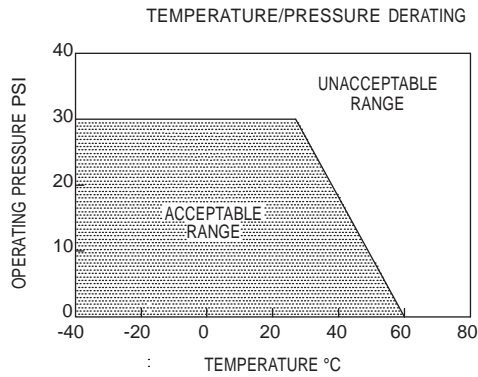

### OPERATING PRINCIPLE

Ultrasound is sound with a frequency greater than the upper limit of human hearing; approximately 20 kilohertz. The BULLET contains an ultrasonic transducer and a temperature sensing element. The ultrasonic transducer transmits ultrasound wave pulses through air directed towards the material of which the level is desired. The ultrasound waves then reflect off of the material as an echo and travel back to the transducer. The level of the material is determined by the transit time of the ultrasound wave pulse from the sensor to material and for the echo to come back to the sensor. The speed of sound through air is sensitive to the air temperature. The BULLET uses the temperature sensing element to compensate for air temperature changes.

The BULLET incorporates patented surface processing technology and adaptive signal processing. Surface processing technology filters out all signal obstructions that may be in the tank creating an effective beam diameter of only 3" (7.6 cm). This beam diameter is a straight column and not cone shaped like competitor units. Adaptive signal processing continuously optimizes sensor power, output filtering, and environmental noise rejection.

### INSTALLATION

#### Unpacking

Remove the BULLET from the shipping carton and inspect for damage. If damage is found, notify the carrier immediately.

#### Materials

The BULLET may be used to detect level of a variety of materials. Since the sensing technology is non-contact it is well suited for corrosive, coating, slurry, or sticky media. The hazardous approval rating also makes the unit ideal for use with hazardous rated applications. Please see the specifications section for hazardous approval classifications.

#### Mounting Location

- The process temperature and ambient temperature must be within the specified limits.
- The probe must be located away from tank inlets or chutes where material may fall on the probe during filling or emptying.
- The probe must be located at least 3" (7.6 cm) away from the tank side wall.
- The probe cannot be used in vacuum applications.
- The probe must be installed vertically and perpendicular to the media surface.
- Make sure the covers are accessible to allow for programming, wiring, and ability to see the display.

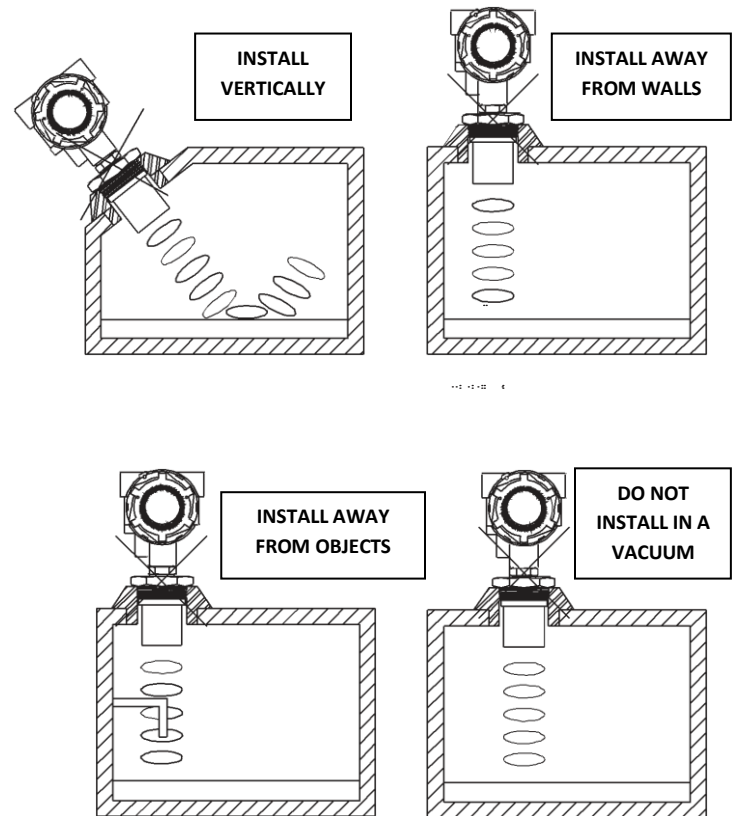
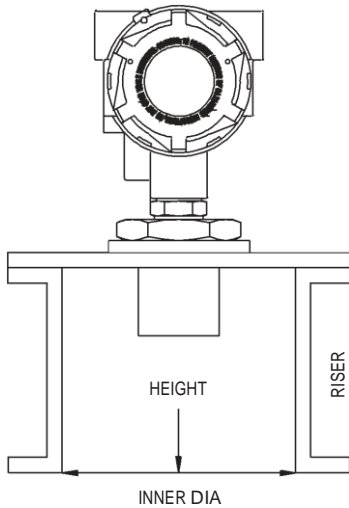

Figure 1: Unsuitable Mounting Locations

## MOUNTING FITTING

Fittings should be selected that minimize the installation height of the transmitter so that mounting hardware does not interfere with the acoustic signal. If the installation does require a riser then the transmitter may be elevated up to 12" (30 cm) in a 6" (15 cm) diameter riser, 8" (20 cm) in a 4" (10 cm) diameter riser, and 3" (7.6 cm) in a 2" (5 cm) diameter riser, see Figure 2. A stand pipe may be used to dampen turbulence or separate surface foam. Use a minimum 3" diameter pipe and cut to the desired length of the transmitter span with a 45° notch at the bottom. A ventilation hole needs to be created at the top of the pipe within the 8" (20 cm) blind zone, see Figure 3.



**Figure 2: Riser Mounting**

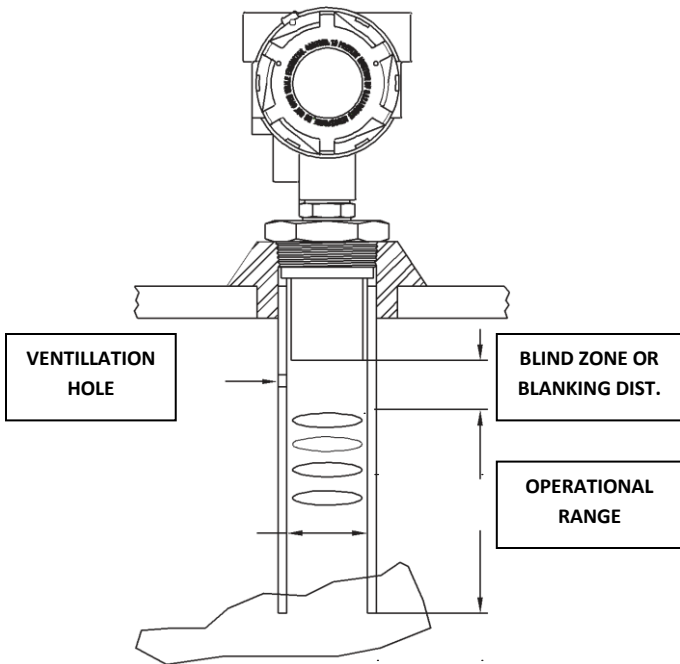

**Figure 3: Stand Pipe Mounting**

## ELECTRICAL CONNECTION



**CAUTION:** Do not exceed the specified supply voltage rating. Permanent damage not covered by the warranty may result. This unit is not designed for AC voltage operation.

**NOTE:** Installation must be made in accordance with local codes and regulations. When fishing wire through the conduit connection do not allow the wire to touch or press on components on the boards. Damage to the circuitry may result. Make sure that the wire is routed so it will not interfere with the calibration switches.



**CAUTION: Hazardous Area Use:** Plug any unused conduit openings. Plug must engage a minimum of 5 threads. Use a conduit seal within 18" (45.7 cm) of conduit entry. Disconnect power before opening, servicing, programming, installing, or removing.

The BULLET provides two 1/2" NPT female ports for conduit connection. The conduit connection must be made such that condensation is not allowed to enter the sensor housing. If necessary install a conduit breather drain in a separate conduit body to prevent buildup of moisture. If nonmetallic conduit is used the protective ground may be connected to the internal ground connection screw.

The BULLET transmitter is designed as a two wire 4-20 mA device. Connection to the board is through a two pin terminal block. The circuitry is polarized so the positive must be connected to terminal 1 and the negative must be connected to terminal number 2. It is recommended that shielded twisted pair wire be used if the potential exists for interference from external noise sources. Ground the shield at the case using the internal ground screw and leave the other end of the shield open. Do not use the shield as one of the current loop conductors.

## Power Supply

The transmitter requires a minimum of 18 Volts DC at its connection for proper operation, and a maximum of 28 Volts. Choose a power supply with a voltage and current rating sufficient to meet this power specification under all operational conditions. If the supply is unregulated, make sure that the output voltage remains within the required voltage range under all power line conditions. Ripple on the supply should not exceed 100 mV.

## Loop Resistance

The maximum allowable loop resistance is dependent on the power supply voltage. The maximum loop voltage drop must not reduce the transmitter voltage below the 18 Volt minimum. The maximum loop resistance can be calculated using the following equation:

$$R_{MAX} = \frac{V_{PS} - 18.0}{20mA}$$

Where  $V_{PS}$  is the power supply voltage.

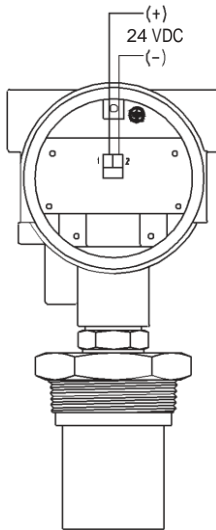

**Figure 4: Electrical Wiring Diagram**

## SETUP & CALIBRATION

Four buttons are provided for all setup and calibration operations. All settings are stored in nonvolatile memory so they will not be lost if the power is removed.

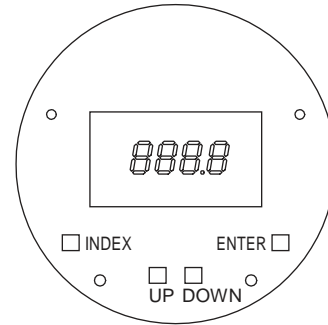

**Figure 5: Display and Programming Buttons**

## KEY FUNCTIONS

### **INDEX**

Pressing the **INDEX** button advances the display to the next menu item.

### **ENTER**

Pressing the **ENTER** button for approximately two seconds will end operating mode and enter programming mode. In programming mode press the **ENTER** button will store the value of menu items once they are changed to a new value.

### **UP**

Pressing the **UP** button increments a value in programming.

### **DOWN**

Pressing the **DOWN** button decrements a value in programming.

### **UP & INDEX**

Pressing the **UP** and **INDEX** simultaneously will allow faster increments in a value for programming.

### **DOWN & INDEX**

Pressing the **DOWN** and **INDEX** simultaneously will allow faster decrements in a value for programming.

## **PROGRAMMING MENU SELECTIONS**

The transmitter has two modes: operating and programming. In the normal operating mode the transmitter will display the liquid height. The unit comes factory calibrated with the output defaulted to 4 mA equal to the maximum range and 20 mA equal to the minimum range of the transmitter model. In the programming mode the transmitter will display the programming menus and choices. When in programming mode the transmitter will hold the last current value. The value will not change until the transmitter is returned to operating mode via RUN in the menu structure.

**To enter the programming mode press and hold the ENTER button for approximately 5 seconds.**

Once in programming mode there are the following top menu selections: **DISPLAY**, **TANK**, **OUTPUT**, **TARGET CAL**, **VALUES**, **HELP**, and **RUN**.

Pressing the **INDEX** button will increment to the next top menu and pressing the **ENTER** button will enter the menu for programming changes.

## **DISPLAY MENU**

Press **INDEX** to advance to the next menu time. Press **ENTER** to retain the value.

### **MEASURE**

Sets the transmitter output: Select **LIQUID** or **AIR**. Factory default is **LIQUID**.

- LIQUID** Output will be the height of the liquid in the tank.
- AIR** Output will be the height of the air above the liquid in the tank.
- EXIT** Exit without making changes.

### **UNITS**

Sets the transmitter display and output unit of measure. Select **INCHES**, **FEET**, **CM**, or **METER**. Factory default is **INCHES**.

- INCHES** Display and output will be in inches.
- FEET** Display and output will be in feet.
- CM** Display and output will be in centimeters.
- METER** Display and output will be in meters.
- EXIT** Exit without making changes.

### **SHOW**

Sets the transmitter display for distance measure or percentage measure. Select **DISTANCE** or **PERCENT**. Factory default is **DISTANCE**.

- DISTANCE** Display will be in units of distance.
- PERCENT** Display will be in percentage of range.
- EXIT** Exit without making changes.

### **HELP**

Displays a guide to the menu items in this menu. Press **ENTER** to display.

### **EXIT**

Exits **DISPLAY** menu and goes back to the top menu. Press **ENTER** to go back to the top menu or press **INDEX** to loop back through the **DISPLAY** menu options.

## TANK MENU

If the tank dimensions are known these menu item can be used to set the 4 and 20 mA points manually. See Figure 6 below. Press **INDEX** to advance to the next menu item. Press **ENTER** to retain the value.

### **HEIGHT**

Sets the 4 mA value. Program as the distance from the transducer face to the 4 mA value desired (normally the bottom or lowest value of the tank). Factory default is the maximum range of the model. Use the **UP** and **DOWN** buttons to change the value in the length units the unit has been programmed for. The programmed value can be anywhere in the range below **FILL HEIGHT**. If reverse mA is used then this will become the 20 mA value.

### **FILL HEIGHT**

Sets the 20 mA value. Program as the distance from the **HEIGHT** (normally the bottom of the tank) to the 20 mA value desired. Factory default is the maximum range of the model minus the blind zone distance of 8" (20 cm). Use the **UP** and **DOWN** buttons to change the value in the length units the unit has been programmed for. The programmed value can be any- where in the range above **HEIGHT**. The maximum value for **FILL HEIGHT** is the maximum range of the unit minus the blind zone distance of 8" (20 cm). The blind zone distance is automatically subtracted from the **FILL HEIGHT** value programmed. If reverse mA is used then this will become the 4 mA value.

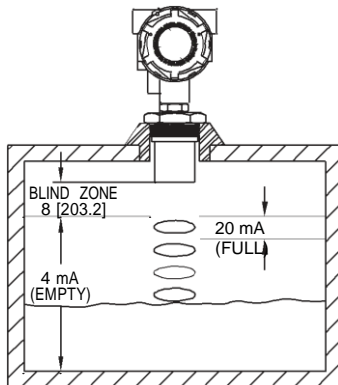

Figure 6: HEIGHT and FILL HEIGHT

### **HELP**

Displays a guide to the menu items in this menu. Press **ENTER** to display.

### **EXIT**

Exits **TANK** menu and goes back to the top menu. Press **ENTER** to go back to the top menu or press **INDEX** to loop back through the **TANK** menu options.

## OUTPUT MENU

Press **INDEX** to advance to the next menu item. Press **ENTER** to retain the value.

### **SAFE MODE**

Sets the output of the transducer for fail-safe mode. The transmitter will output the safe mode programmed setting if the transmitter loses the echo signal. Select 22 mA, 21 mA, 20 mA, 4 mA or HOLD. Factory default value is 22 mA. Unit will resume normal operation when echo signal is again received.

- 22 mA** Output of 22 mA.
- 21 mA** Output of 21 mA.
- 20 mA** Output of 20 mA.
- 4 mA** Output of 4 mA.
- HOLD** Output of last known signal is held.
- EXIT** Exit without making changes.

### **REVERSE MA**

Sets the transmitter output to be forward or reverse acting. Select NORM or REV. Factory default is NORM with 4 mA set at the maximum range of the unit and 20 mA set at the end of the blind zone. See Figure 7 below. NOTE: HEIGHT and FILL H must be set before reversing the output.

**NORM** 4 mA is set to be the bottom of the tank (tank empty) and 20 mA is set to be the height the liquid can go in the tank (tank full).

**REVERSE** 20 mA is set to be the bottom of the tank (tank empty) and 4 mA is set to be the height the liquid can go in the tank (tank full).

**EXIT** Exit without making changes.

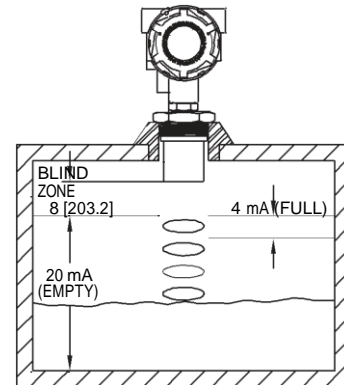

Figure 7: Reverse Output Operation

### **HELP**

Displays a guide to the menu items in this menu. Press **ENTER** to display.

### **EXIT**

Exits **OUTPUT** menu and goes back to the top menu. Press **ENTER** to go back to the top menu or press **INDEX** to loop back through the **OUTPUT** menu options.

## TARGET CAL MENU

Target Calibration sets the tank empty and tank full distances for the transmitter output based on the actual level in the tank. This is good to use if the tank dimensions are unknown or if it is desired to fill and empty the tank for precise measurement points. Press **INDEX** to advance to the next menu time. Press **ENTER** to retain the value.

### **FULL**

Fill the tank to the full liquid level desired. Press **ENTER** and this level will be saved.

### **EMPTY**

Drain the tank to the empty level desired. Press **ENTER** and this level will be saved.

### **HELP**

Displays a guide to the menu items in this menu. Press **ENTER** to display.

### **EXIT**

Exits **TARG CAL** menu and goes back to the top menu. Press **ENTER** to go back to the top menu or press **INDEX** to loop back through the **TARG CAL** menu options.

## VALUES MENU

Displays the current programmed setup for the unit. This is scrolling data that will return to the **VALUES** menu after displaying all the parameters. Values shown are: **MEASUR**, then the setting; **UNITS**, then the setting; **SHOW**, then the setting; **HEIGHT**, then the setting; **FILL H**, then the setting; **SAFE**, then the setting; **REV MA**, then the setting.

### **DIAGNOSTICS**

Displays diagnostic items that may be relevant to the transmitter and its performance in the application. This is scrolling data that will return to the **VALUES** menu after displaying all the parameters. Values shown are **RANGE**, then the setting; **TEMP**, then the setting; **ECHO**, then the setting; **POWER**, then the setting; **VER**, then the setting.

### **RESET**

Resets the programming to factory default settings.

**YES** Resets the programming to factory default settings.

**NO** Exits without making changes.

### **EXIT**

Exits **VALUES** menu and goes back to the top menu. Press **ENTER** to go back to the top menu or press **INDEX** to loop back through the **VALUES** menu options.

### **HELP MENU**

Contains contact information for ECHO Process Instrumentation, Inc..

## MAINTENANCE AND REPAIR

Other than the controls mentioned in this manual there are no user maintenance adjustments or routine servicing required for this product. The unit is not field repairable and should be returned to the factory if service is required. Disassembly or modifications made by the user will void the warranty and could impair the continued safety of the product. If repair is required obtain a Return Merchandize Authorization (RMA) number and send the unit, freight prepaid, to the address below. Please include a detailed description of the problem and conditions under which the problem was encountered.

ECHO Process Instrumentation, Inc.

Attn: Repair Department

70 6<sup>th</sup> Ave

Shalimar, FL 32579 USA

Phone: 850-609-1300

Fax: 850-651-4777

Email: [info@echopi.com](mailto:info@echopi.com)

[www.echopi.com](http://www.echopi.com)

