



FLOW HUNTER II & XDS 03

Open Channel Flow Meter

Instruction Manual

JAN 2011 Edition



ECHO Process Instrumentation, Inc. - PO Box 800 - Shalimar, FL 32579 USA

Phone: 850-609-1300 - Fax: 850-651-4777 - Email: info@echopi.com

ECHO Process Instrumentation, Inc.

FLOW HUNTER II MANUAL

January, 2011 Edition

COPYRIGHT

© ECHO Process Instrumentation, Inc. All rights reserved. No part of this publication may be reproduced, transmitted, transcribed, stored in a retrieval system, or translated into any language in any form without the written permission of ECHO Process Instrumentation, Inc.

WARRANTY AND LIABILITY

ECHO Process Instrumentation, Inc. guarantees for a period of 1 year from the date of delivery that it will either exchange or repair any part of this product returned to ECHO Process Instrumentation, Inc. if it is found to be defective in material or workmanship, subject to the defect not being due to unfair wear and tear, misuse, modification or alteration, accident, misapplication or negligence.

DISCLAIMER

ECHO Process Instrumentation neither gives nor implies any process guarantee for this product, and shall have no liability in respect of any loss, injury or damage whatsoever arising out of the application or use of any product or circuit described herein.

Every effort has been made to ensure accuracy of this documentation, but ECHO Process Instrumentation cannot be held liable for any errors.

TECHNICAL INQUIRIES

Please contact ECHO Process Instrumentation, Inc. for technical support 850-609-1300.

ECHO Process Instrumentation, Inc.

Mail to: PO Box 800, Shalimar, FL 32579 USA

Ship to: 70 6th Ave, Shalimar, FL 32579 USA

Tel: 850-609-1300 Fax: 850-651-4777

Email: info@echopi.com Web Site: <http://www.echopi.com>

Table of Contents

Chapter 1 Introduction.....	4
Features	5
Technical Specification	6
Chapter 2 Installation	7
Dimensions.....	8
Cable Entry	9
Sensor Installation.....	10
Chapter 3 How To Use the FLOW HUNTER II	13
Operating the Controller	13
Button Functions.....	15
Chapter 4 Menu Guide	16
Chapter 5 Digital Communicatin	41
Chapter 6 Maintenance.....	42
Chapter 7 Menu Option Record	43
Appendix I.....	47

About the ECHO FLOW HUNTER II

FLOW HUNTER II is an ultrasonic open channel flow meter that measures water level to calculate flow rate and totalized flow based on the principle that the HEAD (water level above zero reference) is specifically related to flow rate in the Primary Measuring Device (weir or flume).

The ultrasonic flow meter employing non-contact measurement method can be applicable to various fluids, including corrosive fluid. Data Logger function is built in this product, enabling long-term storage of various data, such as head, flow rate, and total flow rate. This data can be accumulated for up to 6 months.

This product can be applicable to the following Primary Measuring Devices.

1. Parshall Flumes
2. Suppressed Rectangular Weirs
3. Contracted Rectangular Weirs
4. V-Notch [Triangular] Weirs. [22.5°, 30°, 45°, 60°, 90°, 120°]
5. Cipolletti Weirs
6. Leopold Lagco Flumes
7. Palmer Bowlus Flumes
8. H Flumes

In addition, 10 point DIY CURVE (X,Y Table) and flow equation ($Q=K*H(PWR)$) are used to measure the flow rate in non-standard open channels.

Features of FLOW HUNTER II

- Non-contact flow measurement - applicable to various fluids
- Applicable to various kinds of channels
- 10 point DIY CURVE function able to conduct flow measurement, regardless of the type of channel
- Digital measurement and display (0.01 m³/h)
- Current output in proportion to flow measurement (4mA ~ 20mA)
- Flow rate setting at 4 - 20mA
- Flow-based pulse output (able to set unit flow rate) - applicable to mechanical flow meter
- 2 programmable SPDT relays
- 5 buttons for convenient and easy programming
- LCD to display operational conditions - convenient setting
- Built-in temperature sensor and temperature compensation function
- Ultrasonic output adjustment and algorithm selection assuring consistent flow measurement
- Automatic detection of bottom distance
- Storage of various data, including water level, flow rate, and total flow rate, for up to 6 months.
- Flow Switch input function, able to force the flow rate at Zero flow [Option]
- Operation with free voltage power, low power consumption

Technical Specification

Physical

Controller	9.45" (W) X 7.28" (HT) (240 X 185 mm)
Sensor	Ø 2.64"(dia) X 2.3"(height) (Ø 67(dia) X 160(height) mm)
Mounting	1" NPT
Weight (sensor, controller)	Aprox. 9 lbs (4.0kg)
Sensor Material	Polypropylene

Environmental

IP Rating (electronics housing)	NEMA 4X, IP65
Max. & Min. temperature (electronics)	-4 °C to +140 °F (-20 to +60°C)
Max. & Min. temperature (transducer)	-4 °C to +158 °F (-20 to +70°C)
Sensor cable length	10m (Standard)

Performance

Resolution	1mm
Range(Flow rate)	0.00gal/min ~ 999,999.0 gal/min
Range(Total flow)	999,999,999 gal
Range(level)	9.85 ~ 118 inch (250 ~ 3000mm)
Beam Angle	8° at -3dB (total)
Response Time	500ms
Displayed Value	Flow rate, Total flow, Level , graphic LCD (128X68 dot)
Temperature Compensation	Fully compensated via integral temperature sensor over entire operational span

Outputs

Analog Output	Qty 2 4-20mA into Max 750Ω (user adjustable) Fault condition Alarm 3.8mA / Hold / 21mA,
Set point Relay	2 SPDT Relays, 1 Relay
Relay capacity	250VAC, 5A
Communication Port	1 point RS-232C/RS485
Pulse output	1 point, open collector

Programming

On-board programming	via 5 tactile push button buttons
-----------------------------	-----------------------------------

Supply

Power supply	90 ~ 260VAC, Less than 15VA (50Hz ~ 60Hz),
---------------------	--

Applicable Channel

Parshall Flumes
Suppressed Rectangular Weirs
Contracted Rectangular Weirs
V-Notch[Triangular] Weirs.[22.5°, 30°, 45°, 60°, 90°, 120°]
Cipolletti Weirs
Leopold Lagco Flumes
Palmer Bowlus Flumes
H Flumes

Special function

10 Point DIY CURVE (X,Y Table)
Flow equation(Q=K*H(PWR))

Chapter 2 Installation

FLOW HUNTER II is composed of one electronics unit and one sensor (transducer)

Power Supply Requirements

The **FLOW HUNTER II** operates from a power supply of 90 ~ 260VAC.

All electronic products are susceptible to electrostatic shock, so follow proper grounding procedures during installation.

When choosing a location to mount the sensor, bear in mind the following:

- For easy access to the LCD display and programming buttons mount it where it is easily accessible.
- The ultrasonic signal path should be free of falling material & obstructions such as pipes, beams etc.
- The sensor should be mounted at least 12" or 30cm above the maximum level of the water and be perfectly perpendicular to the surface.
- The mounting surface should be vibration-free.
- The ambient temperature of the sensor is between -4°F and 158°F.
- There should be no high voltage cables or electrical inverters close by.

Dimensions

XDS 03 Sensor (mm)

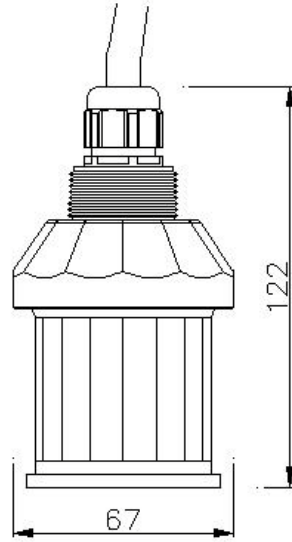

Electronics (mm)

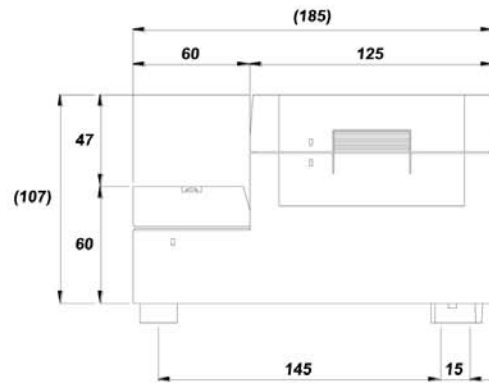
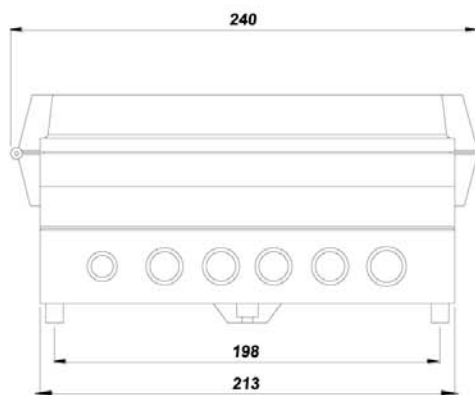
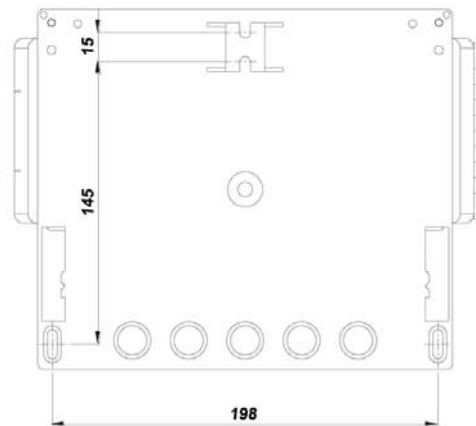
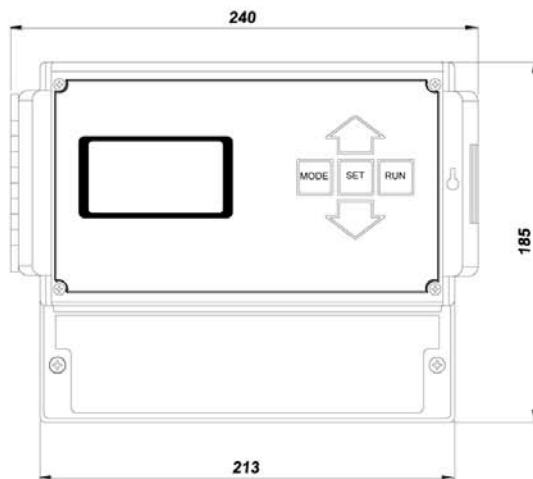

Cable Entry

There are 20 terminals for controller and 3 terminals for power as follows:

Input & Output Terminal

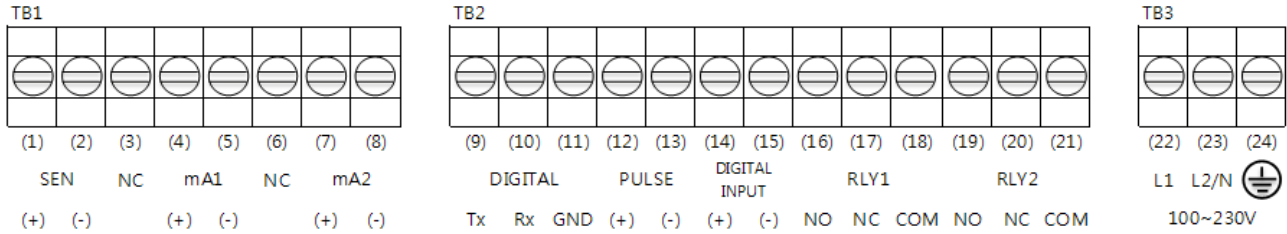

Terminal	No.	Function	Note
SEN(+)	1	Connect to +cable of sensor	
SEN(-)	2	Connect to shield cable of sensor	
NC	3	Not in Use	
mA(+)	4	Analog output (+)	OUTPUT 1
mA(-)	5	Analog output (-)	
NC	6	Not in Use	
mA(+)	7	Analog output (+)	OUTPUT 2
mA(-)	8	Analog output (-)	
DIGITAL TX	9	When using RS232C interface, connection to RS232's transmitter. When using RS485, connection to Y.	
DIGITAL RX	10	When using RS232C interface, connection to RS232's receiver. When using RS485, connection to Z.	
DIGITAL GND	11	Digital communication GROUND	
PULSE (+)	12	Pulse output (+); based on set increments	
PULSE (-)	13	Pulse output (-)	
DIGITAL INPUT (+)	14	Not in Use	
DIGITAL INPUT (-)	15	Not in Use	
RLY 1 NO	16	Relay _1 Normally Open contact point.	
RLY 1 NC	17	Relay _1 Normally Closed contact point.	
RLY 1 COM	18	Relay _1 Common contact point.	
RLY 2 NO	16	Relay _2 Normally Open contact point.	
RLY 2 NC	17	Relay _2 Normally Closed contact point.	
RLY 2 COM	18	Relay _2 Common contact point.	
L1	24	AC power connection	100 – 230 VAC
L2/N	23	AC power connection	
⊕	22	GND	

NOTE: Consult Factory for DC Wiring (option).

Sensor Installation

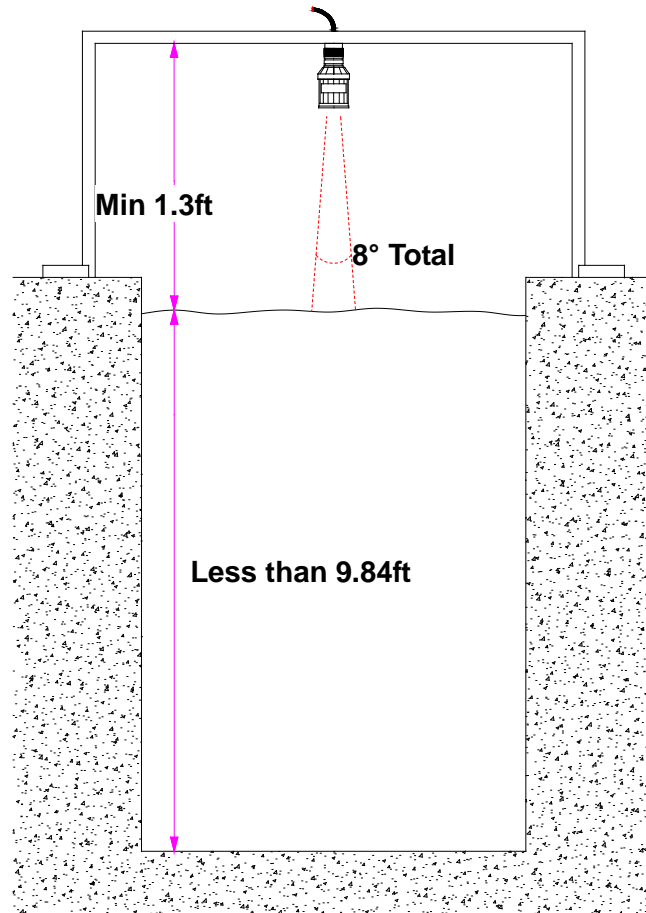

In order to prevent malfunctions and assure accurate measurement, installation should be conducted under consideration of the following points.

- 1) There should be no obstructions within the range of the 8° beam angle.**
- 2) It should be installed at right angles to the water surface. (The sensor should be vertical to the floor.)**
- 3) Input accurate bottom distance (04. BOTTOM DISTANCE). Bottom Distance is equivalent to EMPTY DISTANCE (Distance from transducer face to Zero Flow Point).**

The sensor should be installed 1.5 ft or more above the maximum possible water level of the channel to be measured.

Weir

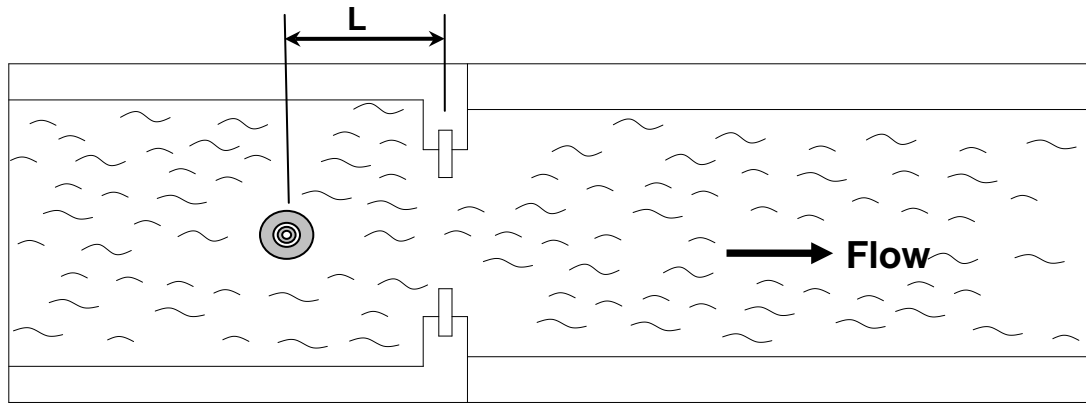

- In the rectangular, triangular (V-Notch), and Cipolletti channels, the sensor should be installed at the top of the channel. Recommendation: $L = \text{Max. height of Head (Span)} \times 4$

Parshall Flume

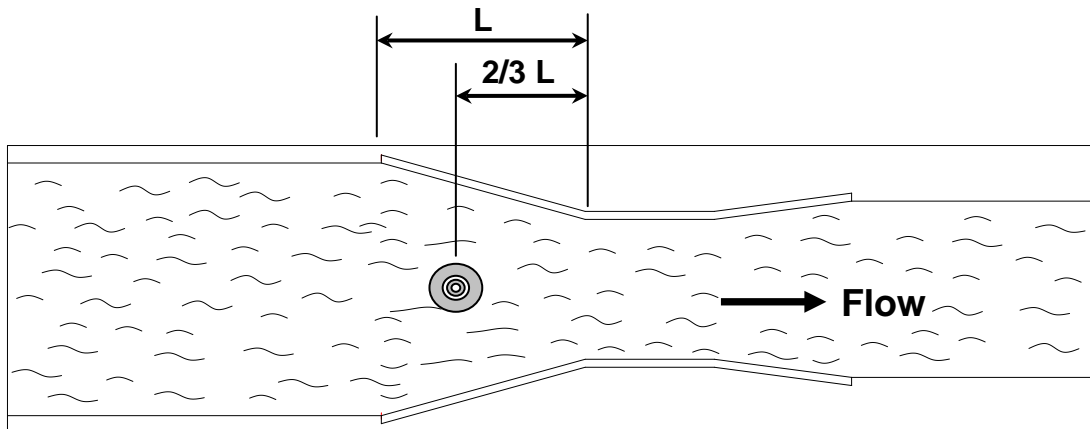

- In the Parshall Flume, the sensor should be installed at a $2/3$ position of the converging section Length (L).

Leopold Lagco Flume

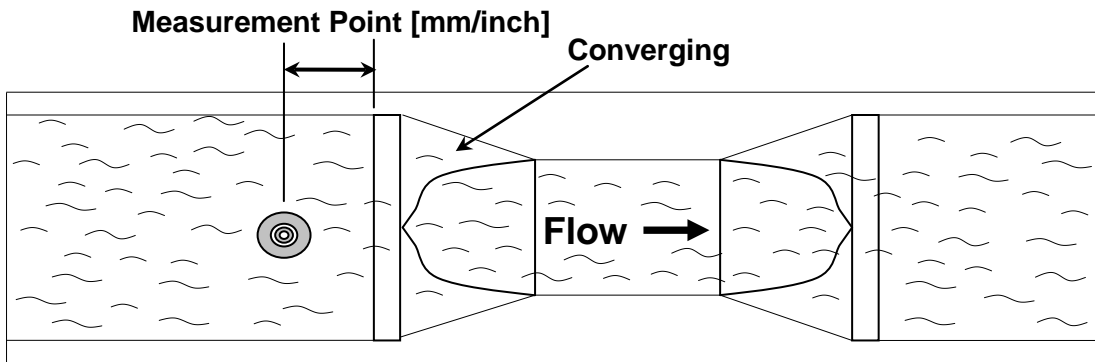

- In the Leopold-Largco Flume, the sensor should be installed at a position distant from Converging Section (corresponding to the distance of measurement point according to Flumes size)

Flume Size		Measurement Point	
mm	inches	mm	inches
100 ~	4~12	25	1.0
380	15	32	1.3
455	18	38	1.5
530	21	44	1.8
610	24	51	2.1
760	30	64	2.5

- Flickering of "DT" at the bottom of the screen at Operation Mode means detection of water level. Therefore, such flickering should be confirmed in the course of installation.
- Sensor should not be exposed to direct sunlight or strong wind (need to cover).
- After installation, operational conditions should be checked again (Power On/Off and display of measurement level).

Chapter 3 How To Use FLOW HUNTER II

DISPLAY IN RUN MODE

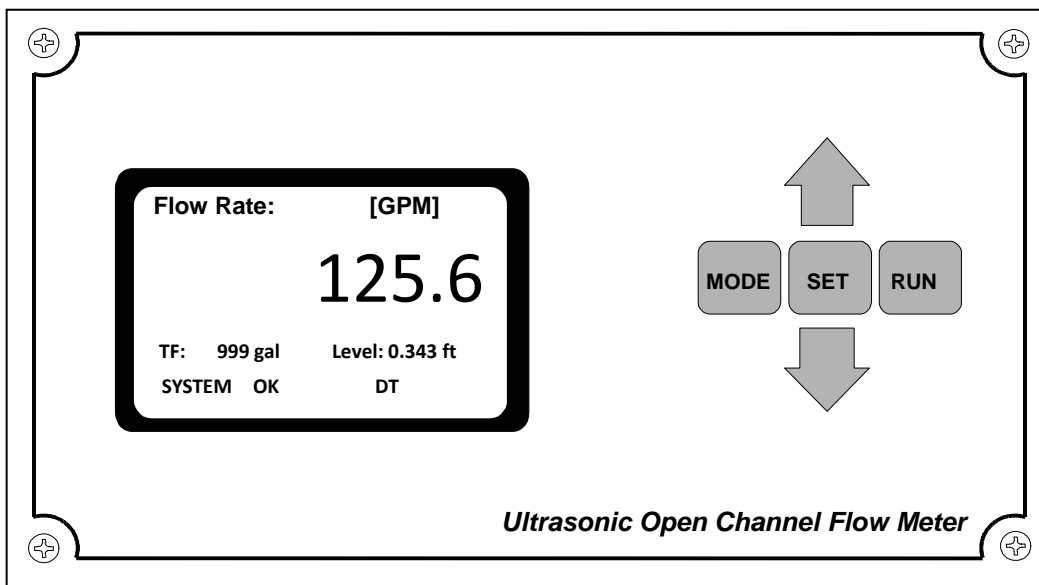

RUN MODE I

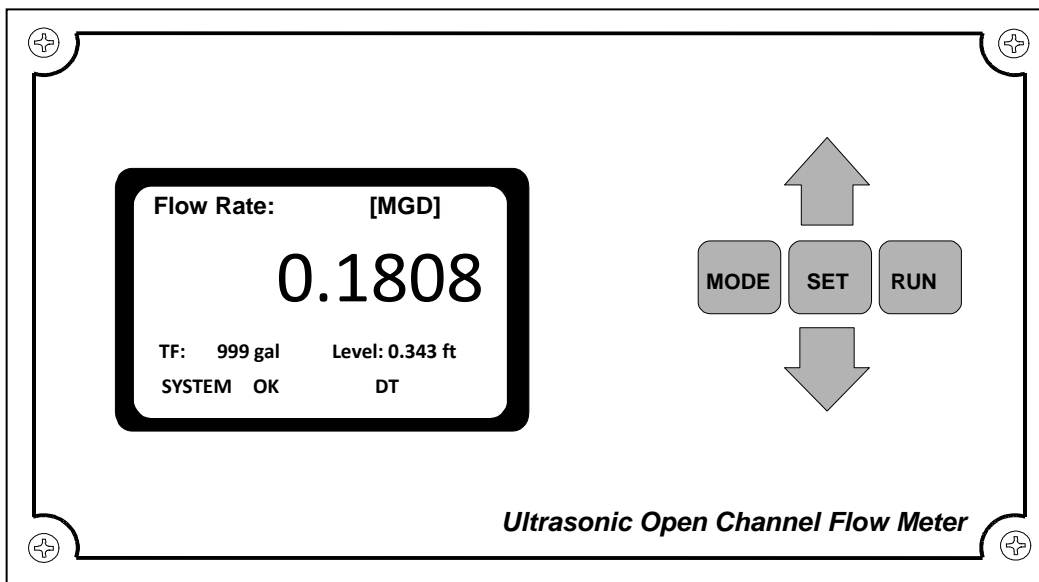

RUN MODE II

- Push [UP] or [DOWN] button in RUN Mode I and RUN Mode II will be displayed. The difference is the flow rate is displayed in MGD vs. GPM. RUN Mode II can be toggled back to Run Mode I by [UP] or [DOWN] button.
- RUN Mode III can be toggled by the [SET] button and shows the flow rate, total flow, total hour, water level, relay condition, and sensor status.
- You can choose Operation Mode I, II or III as you want.

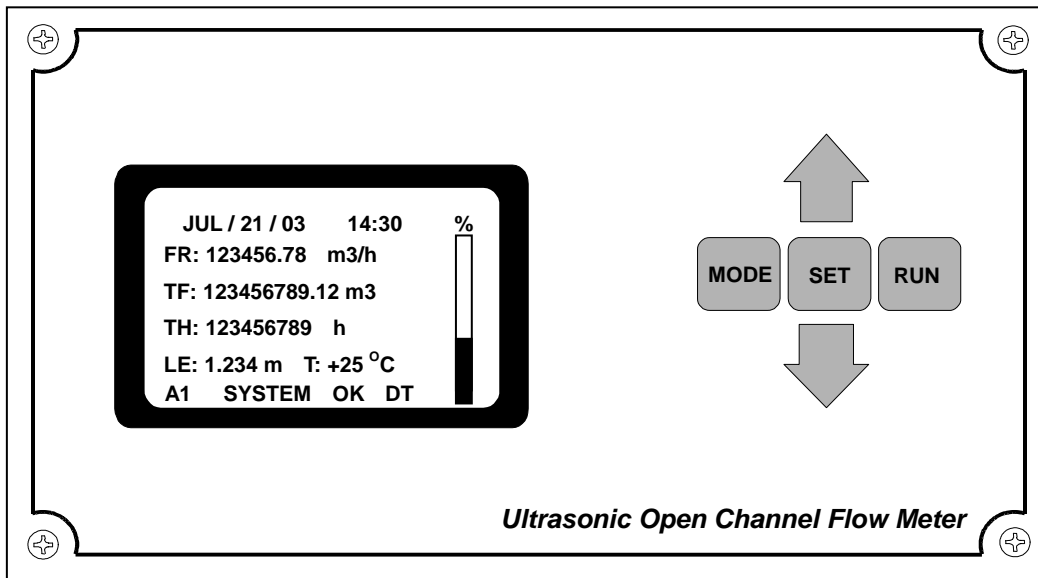

RUN MODE III

- Description of abbreviations displayed

- 1) FR Flow rate measured in gal/m.
- 2) TF Total flow from the set time.
- 3) TH Total hours from the set time.
- 3) LE Measured level from the bottom to the surface in mm.
- 4) T Ambient temperature.
- 5) Bar Bar graph is the ratio of measured flow rate to max. flow rate.

- Description of characters displayed

FLOW HUNTER II shows its RUN MODE conditions on the LCD.

- 1) A1 RELAY1 is ON.
- 2) A2 RELAY2 is ON.
- 3) OK SYSTEM OK is normal.
- 4) FAIL Failure to measure the flow rate.
- 5) DT Flickered on normal measurement of water level.
(meaning normal detection of reflected waves and working very good)
- 6) D Echo detection is okay
- 7) S Searching for Echo
- 8) LE On failure to detect the reflected waves. Loss of Echo

Button Functions

1) MODE Button

- To convert Operation Mode to Program Mode.
- Push MODE button at Operation Mode and PASSWORD CHECK, the first menu of Program Mode, will be displayed.
- Push SET button and Program Mode will be immediately shown.
- At Program Mode, push Up or Down button to move to other menu option.
- Use MODE button to return to menu option after device selection (02. DEVICE SELECTION)

2) UP [↑] and DOWN [↓] Button

- Use this button to change the value of an option selected.
- One push of these buttons leads to increase by one. Continuous push of these buttons results in continuous increase one by one. Further push of this button results in change of the number at tenth or hundredth figures.
- If a specific menu is not selected, this button can be used to change menu options. One push of this button results in return to the previous menu.

3) SET Button

- Use this button to save the values of an option and then, go to the next option selection.

4) RUN Button

- Use this button to return to Operation Mode from Program Mode.

Application Menu Option

Password Check

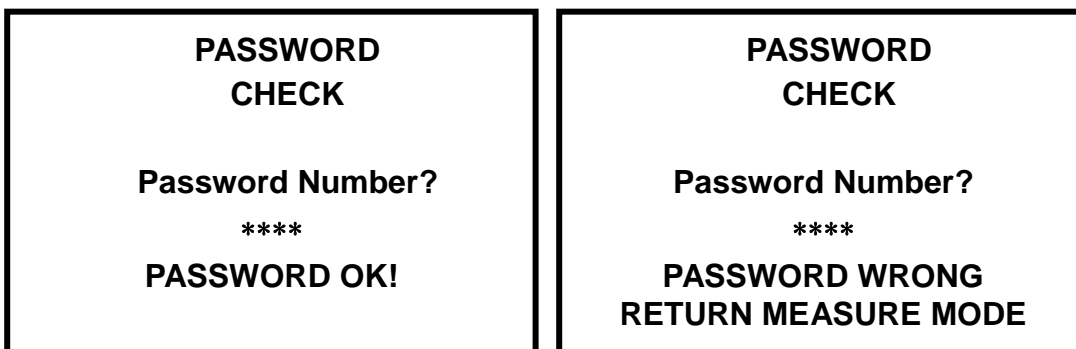

< When password is confirmed >

< When password is not confirmed >

- Push MODE button at Operation Mode and PASSWORD CHECK, the initial menu of Program Mode, will be displayed. This is a function to prevent change of set values by unauthorized persons.
- If the password is wrong, "PASSWORD ERROR!" and "RETURN MEASURE MODE" will be displayed at the same time and it will return to Operation Mode.
- If the password is confirmed, "PASSWORD OK!" will be displayed and it will go to Program Mode.
- The password can be changed at PASSWORD CHANGE. The password numbers can be selected within the range of 0~1000.
- Use ↑ or ↓ to move to a specific menu. Place the cursor (*) at a specific menu and push SET button. Then, you can change the value of the menu.
- If you don't want to change the value, push SET button and then, select another menu option.
- If you want to change the value, push ↑ or ↓ to change it. After change, push SET button to save the set value and then, select another menu.
- If you push RUN in the course of selecting an option, Program Mode is converted into RUN Mode.

1. SW VERSION

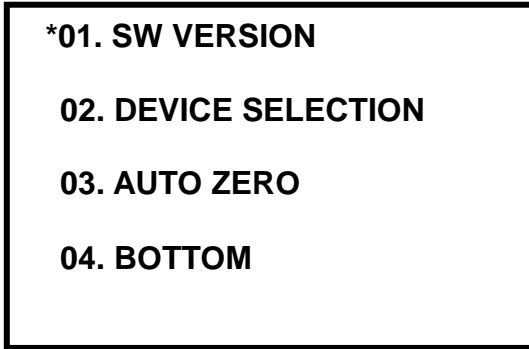

- This menu shows the Software version of the unit.

2. Device Selection

Factory Set = 1

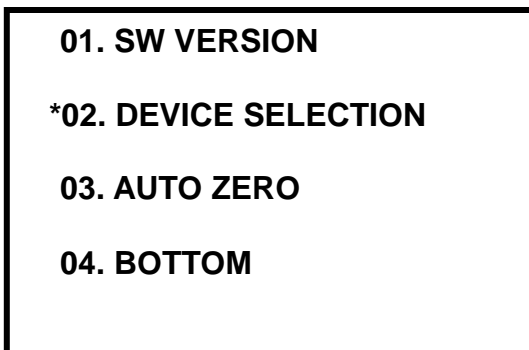

- This is an option for Primary Measuring Device selection. Select the PMD first and then input parameters.
- Place the cursor at this menu. Push SET button and the following screen I will be displayed. The initial value is 1. (Setting range: 1~8, Unit: 1)

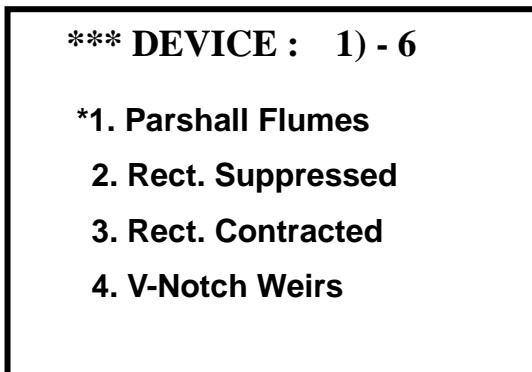

< 2. DEVICE SELECTION Screen I >

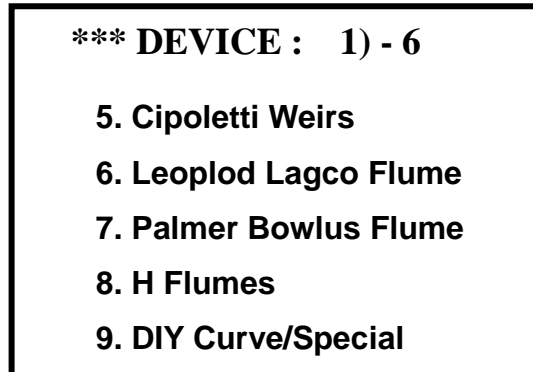

< 2. DEVICE SELECTION Screen II >

- At Program Mode, push ↑ or ↓ to place the cursor (*) at a specific menu and push SET button to go to

the mode for change of the relevant device.

- Push ↓ at No. 4 and Screen II showing No. 5 to 8 will be displayed. Also, push ↑ at No. 1 and the cursor will go to No. 8.
- Push MODE button to return to upper-level menu option.
- On selection of 2. DEVICE SELECTION menu, the channel and max. flow rate value able to measure in the channel with the relevant device will be automatically set.
- When the type of channel is changed during measurement, the previously set values will be lost and values for menus (No. 7, 8, 9, 11, 14) will be initialized as those for the changed channel.

Parshall flumes

Factory Set = 1

1. Parshall Flumes

**** Flume Selection: 1**

1 : 1in.	6 : 1ft.	11 : 5ft.
2 : 2in.	7 : 1.5ft.	12 : 6ft.
3 : 3in.	8 : 2ft.	13 : 8ft.
4 : 6in.	9 : 3ft.	14 : 10ft.
5 : 9in.	10 : 4ft.	15 : 12ft.

- Select Parshall Flumes and push SET button. Then, the menu for flume selection will be displayed as shown in the above figure.
- Use ↑ or ↓ to select the relevant Parshall Flume and push SET button to save the set value and return to main menu. (Setting range: 1~15, Unit: 1)
- Measurable maximum height is automatically set.

Parshall Flume	Max. Height [mm]	Parshall Flume	Max. Height [mm]
1"	180	9"	600
2"	180	1~8 ft	760
3"	450	10 ft	1060
6"	450	12 ft	1370

Rect. Suppressed

Factory B = 1, D = 1, H = 1m

2. Rect. Suppressed

**** Crest Length: 1**

1 : 1ft.	2 : 1.5ft.	3 : 2ft.
4 : 2.5ft.	7 : 3ft.	6 : 4ft.
7 : 5ft.	8 : 6ft.	9 : 8ft.
10 : 10ft.		

- Select Rect. Suppressed and push SET button. Then, the menu for selection of the rectangular weir will be displayed as shown in the above figure.
- Use ↑ or ↓ to select the relevant Rect. Suppressed and push SET button to save the set values and return to main menu option. (Setting range: 1~10, Unit: 1)
- Measurable maximum height is automatically set.

Rect. Suppressed	Max. Height [mm]	Rect. Suppressed	Max. Height [mm]
1 ft	150	4 ft	600
1.5ft	220	5 ft	750
2 ft	300	6 ft	900
2.5 ft	370	8 ft	1200
3 ft	450	10 ft	1500

Rect. Contracted

Factory Set B = 1
 Factory Set D = 1
 Factory Set b = 1
 Factory Set H = 1m

3. Rect. Contracted

**** Crest Length: 1**

1 : 1ft. 2 : 1.5ft. 3 : 2ft.
4 : 2.5ft. 7 : 3ft. 6 : 4ft.
7 : 5ft. 8 : 6ft. 9 : 8ft.
10 : 10ft.

- Select Rect. Contracted and push SET button. Then, the menu for selection of the rectangular weir will be displayed as shown in the above figure.
- Use ↑ or ↓ to select the relevant Rect. Contracted and push SET button to save the set values and return to main menu. (Setting range: 1~10, Unit: 1)
- Measurable maximum height is automatically set.

Rect. Suppressed	Max. Height [mm]	Rect. Suppressed	Max. Height [mm]
1 ft	150	4 ft	600
1.5ft	220	5 ft	750
2 ft	300	6 ft	900
2.5 ft	370	8 ft	1200
3 ft	450	10 ft	1500

V-Notch Weirs [Triangular]

Factory Set = 0.600m

4. V-Notch Weirs

**** Weir Selection: 1**

1 : 22.5° 2 : 30° 3 : 45°
4 : 60° 5 : 90° 6 : 120°

- Select V-Notch Weirs and push SET button. Then, the menu for selection of the triangular weir will be displayed as shown in the above figure.
- Use ↑ or ↓ to select the relevant V-Notch Weir and push SET button to save the set values and return to menu option. (Setting range: 1~6, Unit: 1)
- Measurable maximum height is automatically set at 600 mm.

Cipolletti Weirs [Trapezoidal Weirs]

Factory Set = 0.600m

5. Cipolletti Weirs

**** Weir Selection: 1**

1 : 1ft. 2 : 1.5ft. 3 : 2ft.
4 : 2.5ft. 7 : 3ft. 6 : 4ft.
7 : 5ft. 8 : 6ft. 9 : 8ft.
10 : 10ft.

- Select Cipolletti Weirs and push SET button. Then, the menu for selection of the weir will be displayed as shown in the above figure.
- Use ↑ or ↓ to select the relevant Cipolletti Weir and push SET button to save the set values and return to menu option. (Setting range: 1~10, Unit: 1)
- Measurable maximum height is automatically set.

Cipolletti Weirs	Max. Height [mm]	Cipolletti Weirs	Max. Height [mm]
1 ft	150	4 ft	600
1.5ft	220	5 ft	750
2 ft	300	6 ft	900
2.5 ft	370	8 ft	1200
3 ft	450	10 ft	1500

Leopold Lagco Flumes

Factory Set = 1

6. Leopold Lagco Flumes

**** Flume Selection: 1**

**1 : 4in. 2 : 6in. 3 : 8in.
4 : 10in. 5 : 12in. 6 : 15in.
7 : 18in. 8 : 21in. 9 : 24in.
10 : 30in.**

- Select Leopold Lagco Flumes and push SET button. Then, the menu for selection of the flume will be displayed as shown in the above figure.
- Use ↑ or ↓ to select the relevant Leopold Lagco Flume and push SET button to save the setting values and return to menu option. (Setting range: 1~10, Unit: 1)
- Measurable maximum height is automatically set.

Leopold Lagco Flumes	Max. Height [mm]	Leopold Lagco Flumes	Max. Height [mm]
4 inch	70	15 inch	270
6 inch	100	18 inch	320
8 inch	130	21 inch	380
10 inch	180	24 inch	420
12 inch	210	30 inch	530

Palmer Bowlus Flumes

Factory Set = 1

7. Palmer Bowlus Flumes

**** Flume Selection: 1**

**1 : 4in. 2 : 6in. 3 : 8in.
4 : 10in. 5 : 12in. 6 : 15in.
7 : 18in. 8 : 21in. 9 : 24in.
10 : 27in.**

- Select Palmer Bowlus FLume and push SET button. Then, the menu for selection of the flume will be displayed as shown in the above figure.
- Use ↑ or ↓ to select the relevant Palmer Bowlus Flume and push SET button to save the setting values and return to menu option. (Setting range: 1~10, Unit: 1)

H Flume

8. H Flumes	
** Flume Selection: 1	
1) 0.5H	5) 2.0H
2) 0.75H	6) 2.5H
3) 1.0H	7) 3.0H
4) 1.5H	8) 4.5H

8. H Flumes	
** Flume Selection: 9	
9) 0.4H	12) 1.0H
10) 0.6H	13) 3.0H
11) 0.8H	14) 4.0H

- Select H Flumes and push SET button. Then, the menu for selection of the flume will be displayed as shown in the above figure.
- Use ↑ or ↓ to select the relevant H Flume and push SET button to save the setting values and return to menu option. (Setting range: 1~14, Unit: 1)

DIY Curve / Special (DIY Curve is "Do It Yourself" or is the same as X,Y Table)

Factory Set = 1

9. DIY Curve/Special
** Selection: 1
1 : DIY CURVE
2 : Q=K*H(PWR)
3 : Rectangular Weir

- Select DIY Curve / Special and push SET button. Then, an option for selection of 1. DIY Curve, 2. $Q=K*H*PWR$, or 3. Rectangular Weir will be displayed as shown in the above figure.
- This menu is used for measurement of flow rate, regardless of the type of device.
 1. DIY Curve: This option equally divides the known level-based flow rate into 10 parts and measures the flow rate according to change of level.
 2. $Q=K*H(PWR)$: This option inputs constant values, K and PWR, to an exponentially changing device and measures the flow rate.
 3. Rectangular Weir: This option selects Crest Length of all Rectangular Weirs in mm unit and measures the flow rate.
- Use ↑ or ↓ to select the relevant special option and push SET button to save the set values and return to menu option. (Setting range: 1~3, Unit: 1)

DIY Curve / Special

1. 10 POINT DIY CURVE		
MAX. HEIGHT: 1.234ft		
1) 0.1H:	123456.0	gal/m
2) 0.2H:	123456.0	gal/m
3) 0.3H:	123456.0	gal/m
4) 0.4H:	123456.0	gal/m

1. 10 POINT DIY CURVE		
5) 0.1H:	123456.0	gal/m
6) 0.2H:	123456.0	gal/m
7) 0.3H:	123456.0	gal/m
8) 0.4H:	123456.0	gal/m
9) 0.4H:	123456.0	gal/m
10) 0.4H:	123456.0	gal/m

- Select 1. DIY Curve and push SET button. Then, an option to input max. height of 1. 10 Point DIY Curve will be displayed as shown in the above figure.
- Use ↑ or ↓ to input measurable maximum height of the installed device and push SET button to save the value and go to an option for input of flow rate at 10% height. (Setting range: 0.1 ~ 99999.9 [gal/m])
- Use ↑ or ↓ to increase or decrease the value and input the relevant flow rate value and then, push SET button to save the flow rate value and go to an option for input of flow rate at 20% height. (Setting range: 0.1 ~ 99999.9 [gal/m])
- Continue inputting the flow rate values corresponding to 30%, 40%, 50%, 60%, 70%, 80%, 90%, & 100%.
- After input of value for 100% with use of ↑ or ↓ button, push SET button to go to 2. DEVICE SELECTION. Push MODE button again to go to menu option.

$Q=K*H(PWR)$

Factory Set = 1.234

2. $Q=K*H(PWR)$	
K Constant	: 1.234
KWR Constant	: 1.234
H: Height [ft]	

- Select 2. $Q=K*H(PWR)$ and push SET button. Then, an option to input constants, K and PWR, will be displayed as shown in the above figure.
- Use ↑ or ↓ to input K constant, known or calculated, and push SET button to save the value and go to an option for input of PWR Constant. (Setting range: 0.001 ~ 9.999)
- In this way, input PWR Constant with use of ↑ or ↓ button and push SET button to save the value and return to 2. DEVICE SELECTION. (Setting range: 0.001 ~ 9.999)
- Push MODE button to return to main menu.

Rectangular Weir

Factory Set = 1

<p>3. Rectangular Weirs</p> <p>*Selection: 1</p> <p>1. Suppressed Weir</p> <p>2. Contracted Weir</p> <p>*Crest Length [ft]:</p> <p>1.234</p>

- Select 3. Rectangular Weirs and push SET button. Then, two options to select the type of rectangular weir, *Selection and *Crest Length [m], will be displayed as shown in the above figure.
- If the weir is the suppressed weir, select 1. Suppressed Weir and push SET button. Then, move to the option for input of Crest Length [m]. (Setting range: 1 ~ 2)
- In this way, select 2. Contracted Weir and set the relevant Crest Length. And push SET button to save the value and return to 2. DEVICE SELECTION. (Setting range: 1 ~ 2)
- Push MODE button to return to menu option.

3. Auto Zero

Factory Set = N/A

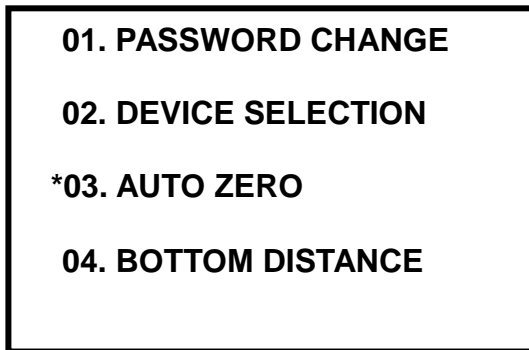

- This is an option for automatic detection of bottom distance from the sensor to the bottom.
- Place the cursor at this option and push SET button. Then, the following screen will be displayed.

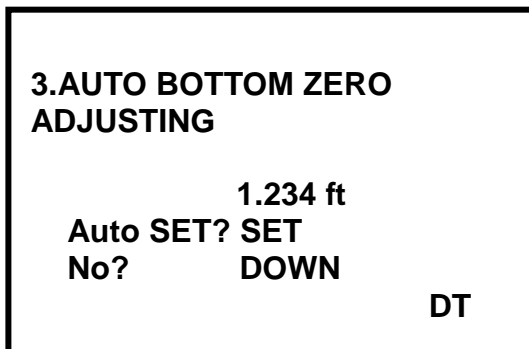

- DT will flicker and the distance will appear. When the distance is stabilized after damping time (measurement response rate), "Auto SET? SET, No? DOWN" will be displayed.
- If you want automatic setting of the measured value, push SET button. If not, push DOWN button and select other menu.

✘ It is important to conduct measurement when the inflow water level is the same as the bottom of the channel and there should be no water overflow in the channel. If you select Auto, Skip step 04. BOTTOM DISTANCE.

4. Bottom Distance

Factory Set = 1.200m

01. PASSWORD CHANGE
02. DEVICE SELECTION
03. AUTO ZERO
***04. BOTTOM DISTANCE**
1.234 ft

- This is an option to manually set the distance from the ultrasonic sensor face to the bottom of the channel. For automatic setting, please refer to 3. AUTO ZERO.
- Since the flow meter installed in open channel is a device to measure the water level and the flow rate, it requires input of accurate distance, otherwise error will occur.
- The unit for the distance is meter (m). Push SET button and the saved value will be displayed. In this condition, the value can be changed. Use ↑ or ↓ to input the desirable value. And push SET button again to save the value and return to main menu.
- Distance detection will not be done beyond the set value. The initial value is 1.200 m.

5. Flow Index

Factory Set = Allowable Max. flow of selected device

***05. FLOW INDEX**
06. FLOW mA SET POINT
07. LEVEL mA SET POINT
08. RELAY 1 SET POINT

- Maximum or minimum flow rate based on the height of the channel can be searched in m³/h or gal/m unit.
- Place the cursor at this menu and push SET button. Then, the following screen will be displayed.

5. FLOW CHANGE VIEW
1. 2 3 4m [1 2 3 4ft]
1 2 3 4 5 6 7.8 9 m³/h
1 2 3 4 5 6 7.8 9 gal/min

- Use ↑ or ↓ to change maximum acceptable height and the flow rate at the height will be displayed. The initial value is the channel-based maximum measurable height (Max Head).

6. FLOW mA Set Point

<p>05. FLOW INDEX</p> <p>*06. FLOW mA SET POINT</p> <p>07. 20mA SET POINT</p> <p>08. RELAY 1 ON POINT</p>

<p>06. FLOW mA SET POINT</p> <p>*(1) 4mA SET POINT xxxxxx.xx gal/m</p> <p>(2) 20mA SET POINT</p>

- This is an option for setting the flow rate value corresponding to 4 mA and 20mA outputs. The set value determines Zero current output. In general, 0 is set. The initial value of 4mA is 0.00 gal/m. (Setting range: 0.00 ~ Max. Flow Rate, Unit: 0.01 gal/m) The initial value of 20mA is 137.60 gal/m. (Setting range: 0.00 ~ Max. Flow Rate, Unit: 0.01 gal/m)
- Push SET button to display the saved value and change it. Use ↑ or ↓ to input the desirable value. Push SET button again to save the value and return to main menu.

7. LEVEL mA Set Point

<p>05. FLOW INDEX</p> <p>06. FLOW mA SET POINT</p> <p>*07. LEVEL mA SETPOINT</p> <p>08. RELAY 1 ON POINT</p>
--

06. LEVEL mA SET POINT

***(1) 4mA SET POINT**
xxxxxx.xx ft

(2) 20mA SET POINT

- This is an option for setting the level value corresponding to the 4mA and 20 mA outputs. The set value determines Span current output. In general, maximum flow rate is set. The initial value is the maximum measurable flow rate (gal/m) of the device set in 02. (Setting range: 0.00 ~ Max. Flow Rate, Unit: 0.01 gal/m)
- Push SET button to display the saved value and change it. Use ↑ or ↓ to input the desirable value. Push SET button again to save the value and return to main menu.

8. Relay1 On Point

Factory Set= 10% of Max. flow value set at option 02 "Device Selection" (Low Alarm On)

05. MAX FLOW

06. 4mA POINT

07. 20mA POINT

***08. RELAY 1 ON POINT**
□□□□□□.□□ gal/m

- When the measured flow rate is below RELAY 1 On Point, the device's RELAY 1 is turned on. The initial value is the flow rate corresponding to 10% of the maximum measurable flow rate of the device set in 02. (Setting range: 0.00 ~ Max. Flow Rate, Unit: 0.01 gal/m)

9. Relay1 Off Point

Factory Set= 20% of Max. flow value set at option 02 "Device Selection" (Low Alarm Off)

***09. RELAY 1 OFF POINT**
□□□□□□.□□ gal/m

10. RELAY 2 ON POINT

11. RELAY 2 OFF POINT

12. RELAY SIMULATION

- When the measured flow rate is above RELAY 1 Off Point, the device's RELAY 1 is turned off.
- The initial value is the flow rate corresponding to 20% of the maximum measurable flow rate of the device set in 02. (Setting range: 0.00 ~ Max. Flow Rate, Unit: 0.01 gal/m)

10. Relay2 On Point

Factory Set= 90% of Max. flow value set at option 02 "Device Selection"

09. RELAY 1 OFF POINT

***10. RELAY 2 ON POINT**
 □□□□□□□.□□ gal/m

11. RELAY 2 OFF POINT

12. RELAY SIMULATION

- When the measured flow rate is above RELAY 2 On Point, the device's RELAY 2 is turned on.
- The initial value is the flow rate corresponding to 90% of the maximum measurable flow rate of the device set in 02. (Setting range: 0.00 ~ Max. Flow Rate, Unit: 0.01 gal/m)

11. Relay2 Off Point

Factory Set= 80% of the Max. flow value set at option 02 "Device Selection"

09. RELAY 1 OFF POINT

10. RELAY 2 ON POINT

***11. RELAY 2 OFF POINT**
 □□□□□□□.□□ gal/m

12. RELAY SIMULATION

- When the measured flow rate is below RELAY 2 Off Point, the device's RELAY 2 is turned off.
- The initial value is the flow rate corresponding to 80% of the maximum measurable flow rate of the device set in 02. (Setting range: 0.00 ~ Max. Flow Rate, Unit: 0.01 gal/m)

<Examples of RELAY ON/OFF POINT Setting>

- RELAY1 & 2 can be used for generation of alarms (low or high flow) and control of water supply pump or drain pump.
- Example 1: Use of RELAY 1 for control of water supply pump (low flow alarm). If RELAY 1 ON POINT is set at 1.00 gal/m and OFF POINT is set at 2.00 gal/m, RELAY 1 is turned on when the flow rate is below 1.00 gal/m. If the water supply pump is turned on in this case, the water level is increased. When the level reaches OFF POINT (2.00 gal/m), RELAY 1 becomes off and the pump stops.
- Example 2: Use of RELAY 2 for control of water drain pump (high flow alarm). If RELAY 2 OFF POINT is set at 1.00 gal/m and ON POINT is set at 2.00 gal/m, RELAY 2 is turned on when the flow rate is above 2.00 gal/m. If the water drain pump is turned on in this case, the water level is decreased. When the level reaches OFF POINT (1.00 gal/m), RELAY 2 becomes off and the pump stops.

12. Relay Simulation

Factory Set =0.00 gal/m

09. RELAY 1 OFF POINT
10. RELAY 2 ON POINT
11. RELAY 2 OFF POINT
***12. RELAY SIMULATION**

- This is an option to check if RELAY is in normal operation after setting 08, 09, 10, and 11 items.
- Place the cursor at this menu and push SET button. Then, the following screen will be displayed.

RELAY SIMULATION

R1 ON : □□□□□□.□□ gal/m
R1 OFF : □□□□□□.□□ gal/m
R2 ON : □□□□□□.□□ gal/m
R2 OFF : □□□□□□.□□ gal/m
FR : □□□□□□.□□ gal/m

R1 R2

- This shows flow rate values set in 08, 09, 10, and 11. Further, virtual flow rates will flicker.
- Use ↑ or ↓ to adjust those virtual values. In this way, operational conditions of R1 and R2 can be checked.
- When it is below R1 ON POINT, RELAY 1 will be turned on and A1 will be displayed. When it is above R1 OFF POINT, RELAY 1 will be turned off and A1 will disappear. When it is above R1 ON POINT, RELAY 2 will be turned on and A2 will be displayed. When it is below R1 OFF POINT, RELAY 2 will be turned off and A2 will disappear.

13.Low Cut Value

Factory Set =0.00 m³ /h

***13. LOW CUT VALUE**
□□□□□□.□□ gal/m

14. HIGH CUT VALUE

15. TIME

16. TOTALIZER

- This is an option to set minimum measurable flow rate. Those below this value will be treated as "0". The initial value is 0.00 gal/m. (Setting range: 0.00 ~ Max. Flow Rate, Unit: 0.01 gal/m)

14.High Cut Value

Factory Set = Max. flow rate

13. LOW CUT VALUE

***14. HIGH CUT VALUE**
□□□□□□.□□ gal/m

15. TIME

16. TOTALIZER

- This is an option to set maximum measurable flow rate. Those above this value will be treated as the maximum flow rate. The initial value is maximum flow rate of the device (gal/m). (Setting range: 0.00 ~ Max. Flow Rate, Unit: 0.01 gal/m)

15.Time

Factory Set = N/A

13. LOW CUT VALUE

14. HIGH CUT VALUE

***15. TIME**
SEP/02/2003/ Tue 16:30

16. TOTALIZER SET

- Push SET button and the month/date/year/day and hour:minute will be displayed. If you don't want to change the value, push SET button again. If you want to change the value, push ↑ or ↓ to change the month. Push SET button again to change the date with use of ↑ or ↓. In this way, the day, hour, and minute can be changed.

16. Totalizer Set

Factory Set = N/A

13. LOW CUT VALUE

14. HIGH CUT VALUE

15. TIME

***16. TOTALIZER SET**

- This is an option to set the initial values of total flow and total time.
- Place the cursor at this menu and push SET button. Then, the following screen will be displayed.

TOTALIZER

1. Total Flow Set
 . **gal/m**

2. Total Time Set
 . **h**

Total Flow Set

- Use ↑ or ↓ to set the integral number of the initial value and push SET button to save value. The decimal number flickers automatically. Use ↑ or ↓ to set the value and push SET button to save the value (Setting range: 0.00 ~ 999999999.99, Unit: 0.01 m3).

Total Time Set

- After completion of setting in 16-1), push SET button and values in Total Time Set will flicker. Use ↑ or ↓ to set total time and then, push SET button to save the value and go to other menu. (Setting range: 0 ~ 999999999, Unit: 1 h)

✘Delete all data previously saved.

17. Pulse Period

Factory Set = 10 mins

*17. PULSE PERIOD 0.10 sec
18. PULSE VALUE
19. LOG PERIOD
20. LOG ERASE

- Period or Increment for storage of total flow data can be set.
- The period for storage of data can be calculated as follows:
Min x 3 = (day) In other words, if 10 minutes are set, data for about 30 days can be saved. When 30 days have passed, total flow data before 30 days are eliminated. Only the current total flow data for 30 days are saved.
- The initial value is 10 min. (Setting range: 1 ~ 60, Unit: 1 min)

18. Pulse Value

Factory Set = 30.00m³

17. PULSE PERIOD
*18. PULSE VALUE □□□ . □□ gal
19. LOG PERIOD
20. LOG ERASE

- This is an option for setting the flow rate value for output of one pulse.
- Pulse output is applicable to total flow meter in pulse count type and this menu determines the flow rate for one pulse. The initial value is 30.00 m³. (Setting range: Max. flow rate per second ~ 100.00, Unit: 0.01 m³)

※Minimum value of setting range is automatically limited against maximum measurable flow rate of the device.

19. Log Period (Increment)

Factory Set = 0.10 sec

17. PULSE PERIOD
18. PULSE VALUE
*19. LOG PERIOD □ . □ □ min
20. LOG ERASE

- This is an option for setting the interval for saving totalized flow. The initial value is 60 minutes. (Setting range: 1 ~60, Unit: 1 min)
- Data logging Period & Point Information:
 - Memory Size: 262,144 Bytes
 - Unit Log Size: 26 Bytes
 - Total Log Points: 262,144/26 = 10,082 points

Examples:

1. When the data logs once per minute, it can be stored for 7 days.
 $10,082 \text{ pt} / (1 \text{ pt/min} * 60 \text{ min/h} * 24 \text{ h/day}) = 7 \text{ days}$
2. When the data logs once per hour, it can be stored for 420 days.
 $10,082 \text{ pt} / (1 \text{ pt/h} * 24 \text{ h/day}) = 420 \text{ days}$

NOTE: Refer to Chapter 5 Digital Communications for data download.

20. Log Erase

Factory Set = N/A

17. PULSE PERIOD
18. PULSE VALUE
19. LOG PERIOD
*20. LOG ERASE

- This is an option for deleting the saved log data.

21. Blanking

Factory Set = 0.35m

<p>*21. BLANKING □ . □ □ □ ft</p> <p>22. TRANSMIT POWER</p> <p>23. OUTPUT DAMPING</p> <p>24. FAIL SAFE CURRENT</p>

- In general, the ultrasonic sensor cannot detect any object within a specific distance from the sensor. The distance is about 0.250 ~ 0.350 m for this product.
- If the user increases this value, false detection arising from an obstacle close to the sensor can be prevented.
- The initial value is 0.350 m. (Setting range: 0.250 ~ 3.000, Unit: 0.001 m)

22. Transmit Power

Factory Set = 3

<p>21. BLANKING</p> <p>*22. TRANSMIT POWER □</p> <p>23. OUTPUT DAMPING</p> <p>24. FAIL SAFE CURRENT</p>

- This is an option for setting the ultrasonic sensor's output. This menu adjusts the output and maintains optimal conditions under operating environments.
- Set low TRANSMIT POWER if there are many obstacles around it. Increase TRANSMIT POWER value for remote measurement.
- At the time of release from the manufacturer, the value is set at 3, which is optimal one for normal operating environments. The initial value is 3. (Setting range: 1 ~ 5, Unit: 1)

23. Output Damping

Factory Set = 2

21. BLANKING
22. TRANSMIT POWER
*23. OUTPUT DAMPING □ □ □ sec
24. FAIL SAFE CURRENT

- This option determines the maximum rate at which the unit will respond to an increase/decrease in level. (Setting range: 1 = 0.1m/min, 2 = 0.5m/min, 3 = 1m/min, 4 = 10m/min)

24. Fail Safe Current

Factory Set = 3.8mA

21. BLANKING
22. TRANSMIT POWER
23. OUTPUT DAMPING
*24. FAIL SAFE CURRENT 3.8mA

- This is an option for setting FAIL SAFE CURRENT. If the reflected wave is not sufficiently received, a specific current different from normal output current is generated to indicate the error:
3.8 mA, HOLD, 21mA
- If measurement is not normally conducted, FAIL SAFE CURRENT is generated after FAIL SAFE TIME has expired.
- If HOLD is set, the flow under HOLD is totalized. In the case of other settings, totalization is not conducted. The initial value is 3.8 mA. (Setting range: 3.8 mA, HOLD, 21 mA).

25. Fail Safe Time

Factory Set = 120 sec

<p>*25. FAIL SAFE TIME □□□ sec</p> <p>26. DETECT THRESHOLD</p> <p>27. 12mA OUTPUT</p> <p>28. FLOW SWITCH</p>
--

- This is an option for setting FAIL SAFE TIME. If the reflected wave is not sufficiently received, FAIL SAFE CURRENT output and ERROR relay operation are held for some time.
- The initial value is 120 sec. (Setting range: 20 ~ 999, Unit: 1 sec)

26. Detect Threshold

Factory Set = 4

<p>25. FAIL SAFE TIME</p> <p>*26. DETECT THRESHOLD □</p> <p>27. FLOW mA TEST</p> <p>28. LEVEL mA TEST</p>

- This is an option for setting threshold for detection of the reflected wave. This menu adjusts the threshold for detection of the reflected wave and maintains optimal conditions under operating environments.
- To reduce the probability of false detection or at an environment generating lots of noise, increase the threshold value. For detection of weak signals, decrease the value. In this way, set the threshold value according to the environmental conditions. The initial value is 4. (Setting range: 3 ~ 15, Unit: 1)

27. MA Output Test

<p>25. FAIL SAFE TIME</p> <p>26. DETECT THRESHOLD</p> <p>*27. FLOW mA TEST</p> <p>28. LEVEL mA TEST</p>

- This is an option for 12 mA output, regardless of measurement result. Such output is used to check operation conditions of current output circuits and interface with other equipment. On returning to RUN Mode, this function is automatically cancelled.

28. Level mA TEST

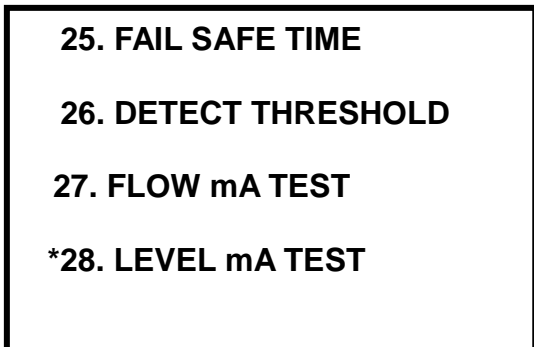

- This is an option for the level output test, regardless of measurement result. Such output is used to check operation conditions of current output circuits and interface with other equipment. On returning to RUN Mode, this function is automatically cancelled.

29. Flow Rate Factor

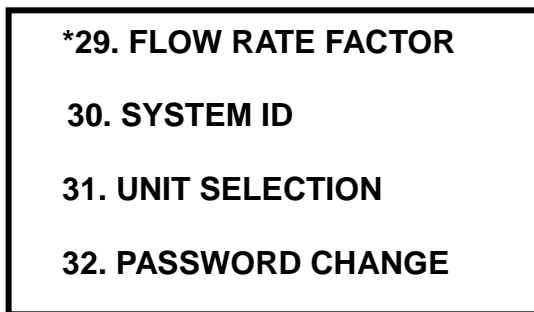

- This function is used when an external flow switch is installed. If the measured flow rate is 0, the flow rate is displayed as 0, regardless of the measured value.
- Place the cursor at this menu and push SET button. Then, the following screen will be displayed.

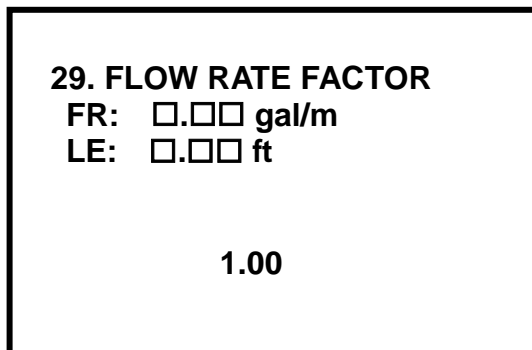

- If a flow switch is installed and used, select "1". If not, select "2".
- Push SET button to display the saved value and change it. Use ↑ or ↓ to select the one you want. Push SET button again to save the value and return to the main menu.

30. SYSTEM ID

29. FLOW RATE FACTOR
*30. SYSTEM ID 0
31. UNIT SELECTION
32. PASSWORD CHANGE

- This menu isn't used in North America.

31. Unit Selection

29. FLOW RATE FACTOR
30. SYSTEM ID 0
*31. UNIT SELECTION
32. PASSWORD CHANGE

- This option is for selecting the units of measurement. It provides two different units, Meter and Feet.

32. Password Change

Factory Set= 0

*32. PASSWORD CHANGE □ □ □ □

- This is an option to change the password. Push ↑ or ↓ to change.
- Push SET button and the changed password will be saved.
- The initial value is 0. (Setting range: 0~1000, Unit: 1)

※Note: If the password is wrong, you cannot go to Program Mode from RUN Mode. Therefore, careful attention should be paid to the new password change. If you forget the password, please contact ECHO Process Instrumentation 850-609-1300.

33. Master Reset

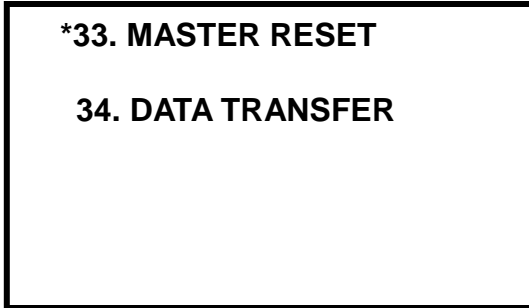

- This is an option for factory reset.
- Push SET button and you can reset the parameter as the factory reset by pressing ↑ or ↓ to change.
- Before using this option, take a note for current parameter settings. The note form is in the end of this manual.

33. Master Reset

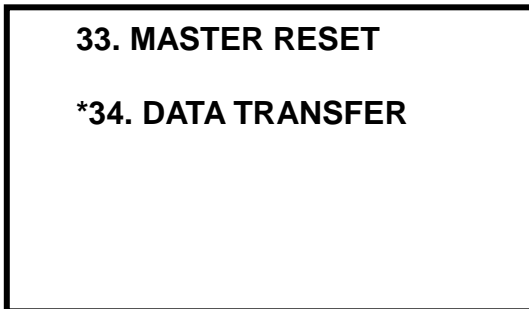

NOTE: Consult factory on obtaining HyperTerminal to download data.

Chapter 5 Digital Communication

The FLOW HUNTER II provides RS232/485 digital communication interface function as an option.

The kinds of data and its format are as follows:

Output Data

1. Baud rate: 4800 bps
2. Data bit: 8 bit
3. Stop bit: 1 bit
4. Parity: no
5. Protocol

Header	Channel ID	Channel value	Separator	Channel ID	Channel value	Separator
2byte	1byte	6byte	1byte	1byte	6byte	1byte
<CR><LF>	A	1ch	,	B	2ch	,

Channel ID	Channel value	Separator	Channel ID	Channel value
1byte	6byte	1byte	1byte	6byte
C	1ch-2ch	,	D	2ch-1ch

- A. 1ch
- B. 2ch
- C. 1ch-2ch
- D. 2ch-1ch

Chapter 6 Maintenance

FLOW HUNTER II does not require any special maintenance work. However, in areas where there are lots of floating matters or viscous sludge, the sensor's surface may be contaminated by them. Therefore, for accurate measurement, it is necessary to install a device to clean the sensor at appropriate interval.

Consult factory if foam regularly appears in Primary Measuring Device. This will cause inaccuracy and possible Loss of Echo.

Chapter 7 Menu Option Record

FLOW HUNTER II

	MENU	RANGE	FACTORY SET	1	2	3	4
01	SW VERSION						
02	DEVICE SELECTION		Parshall 2"				
03	AUTO BOTTOM ZERO	-	-				
04	BOTTOM DISTANCE	0.30~4.00	3.936ft				
05	FLOW INDEX	0.00-2.00	6.51ft				
06	FLOW mA SET POINT	0.00 ~ max	0 gal/m				
07	LEVEL mA SET POINT	0.00 ~ max	0 ft				
08	RELAY1 ON POINT	0.00 ~ max	0 gal				
09	RELAY1 OFF POINT	0.00 ~ max	0 gal				
10	RELAY2 ON POINT	0.00 ~ max	0 gal				
11	RELAY2 OFF POINT	0.00 ~ max	0 gal				
12	RELAY SIMULATION	0.00 ~ max	1.00 gal				
13	LOW CUT VALUE	0.00 ~ max	0 gal				
14	HIGH CUT VALUE	0.00 ~ max	5,602.94gal/m				
15	TIME SET	-	-				
16	TOTALIZER SET	~999999999.99	0.00				
17	PULSE PERIOD	0.01~1.00	0.10 sec				
18	PULSE VALUE	0.1~100.0	30.0 gal				
19	LOG PERIOD	1~60 min.	60 min				
20	LOG ERASE	-	-				
21	BLANKING	0.25~3.00	1.148 ft				
22	TRANSMIT POWER	1,2,3,4,5	3				
23	OUTPUT DAMPING	1 ~ 4	2				
24	FAIL SAFE CURRENT	3.8/H/21.0	3.8mA				
25	FAIL SAFE TIME	20~999	120Sec				
26	DETECT THRESHOLD	3~15	4				
27	FLOW mA TEST		HOLD				
28	LEVEL mA TEST		HOLD				
29	FLOW RATE FACTOR						
30	SYSTEM ID	0~1000	0				
31	UNIT SELECTION	0~1000	0				
32	PASSWORD CHANGE						
33	MASTER RESET						
34	DATA TRANSFER						

< Appendix I > Schematic Diagrams of Channels

A. Parshall Flume

Parshall Flumes are standardized. Depending on the channel width, there are 15 sizes of Parshall Flumes.

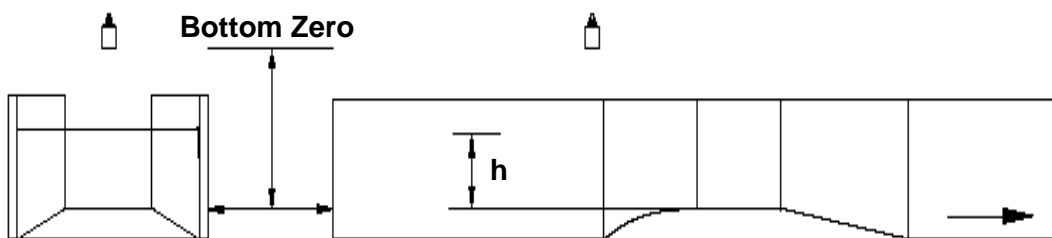
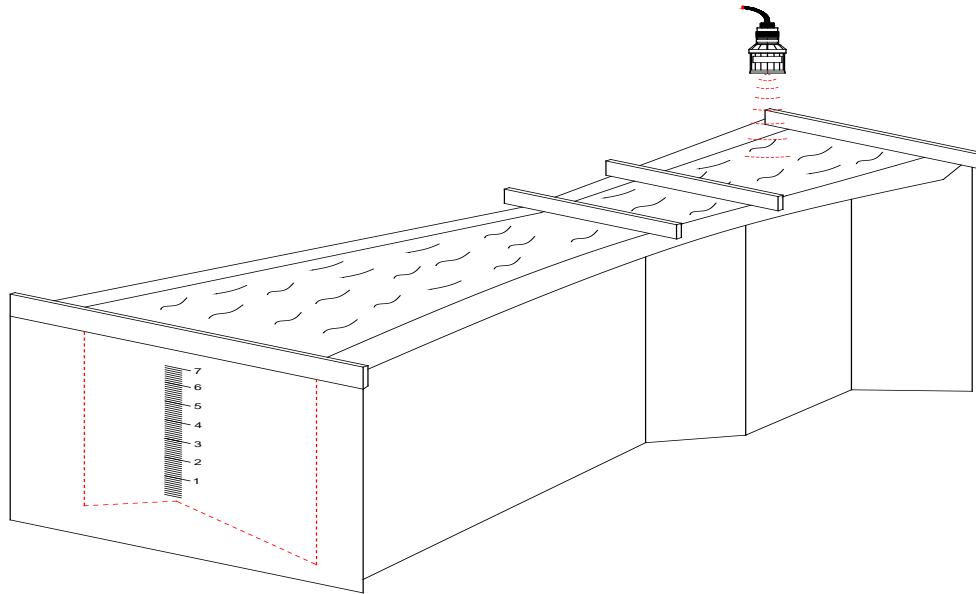

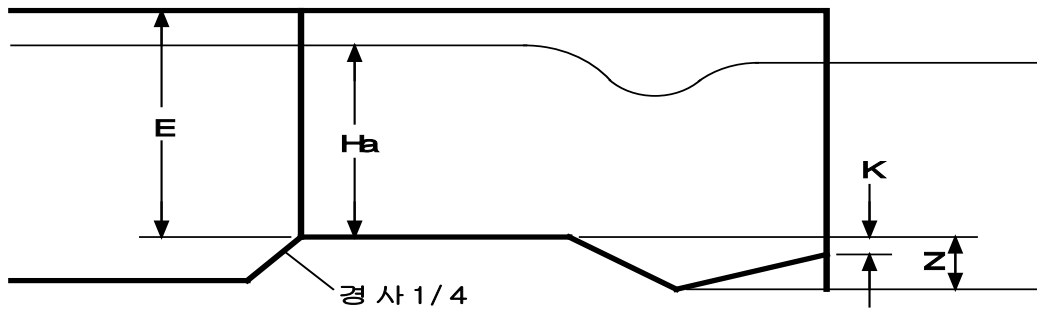
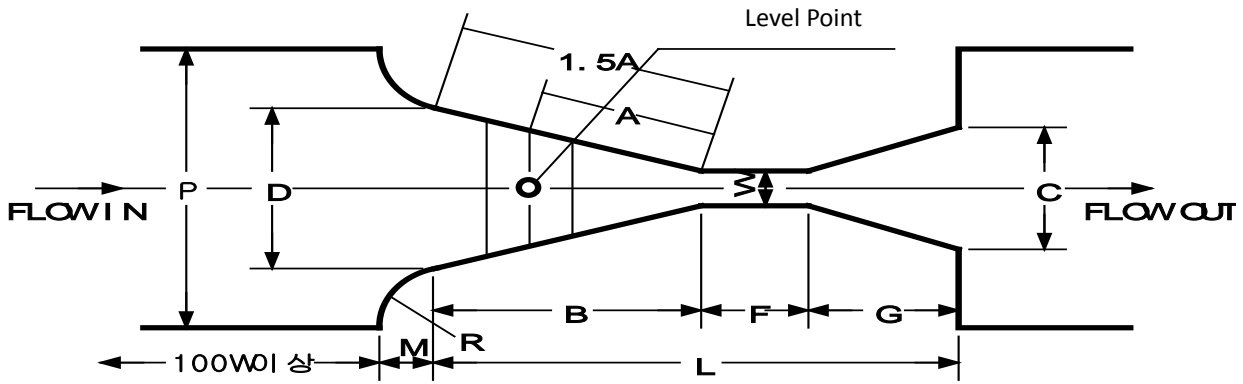

THROAT WIDTH		1 in	2 in	3 in	6 in	9 in	1 ft	8 ft
w		25.4	50.8	75.2	152.4	228.6	304.8	2433.4
FLOW RANGE	MIN. m ³ /h	0.1	0.1	1	1	1	10	357
	MAX. m ³ /h	33	100	194	398	907	1641	14220
A		140	245	311	414	587	914	1626
B		230	360	457	610	864	1343	2391
C		75	118	178	394	381	610	2743
D		145	196	259	397	575	845	3397
E		316	440	610	610	762	914	914
F		95	120	152	305	305	160	160
G		135	200	305	610	457	914	914
K		25	25	25	76	76	76	76
N		57	57	57	114	114	229	229
R		240	240	406	406	406	508	610
M		100	180	305	305	305	381	457
P		330	500	768	900	1080	1492	4172
L		525	680	914	1525	1626	2867	3915

B. Rectangular Weir, Triangular Weir, Suppressed Rectangular Weir, and Cipolletti Weir

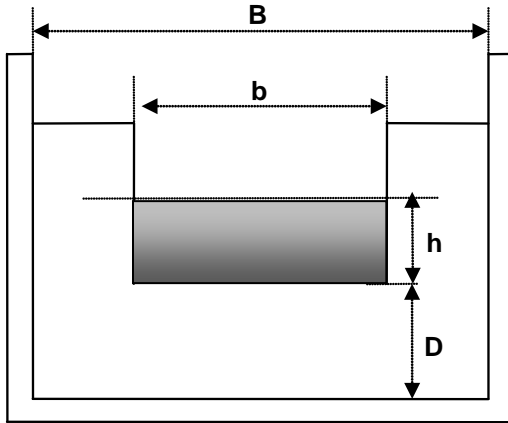

<Rectangular Weir>

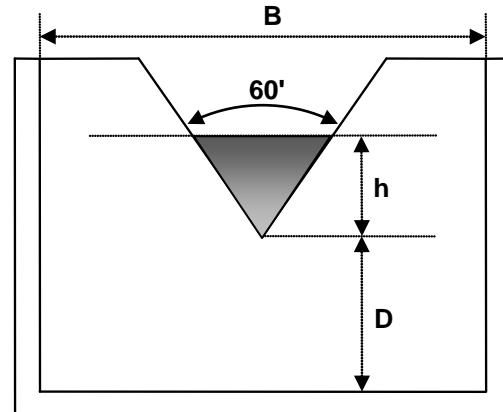

<Triangular Weir (60') >

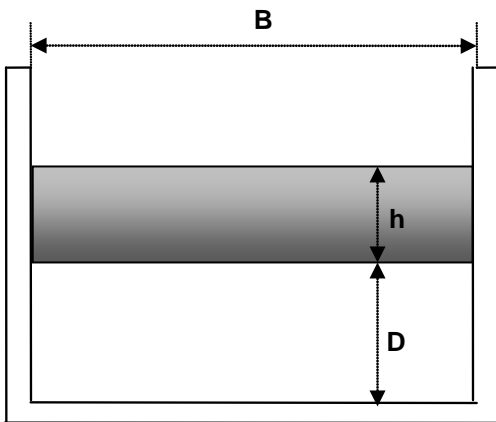

< Suppressed Rectangular Weir >

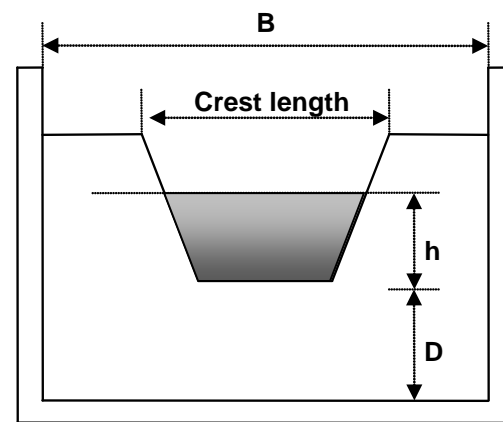

< Cipolletti Weir >

<Fig. B-1 > Front Views of Weirs

h : Water level

B : Suppressed Rectangular Weir's Width (m)

b : Rectangular Weir's Width (m)

D : Thickness from Weir's Bottom (m)

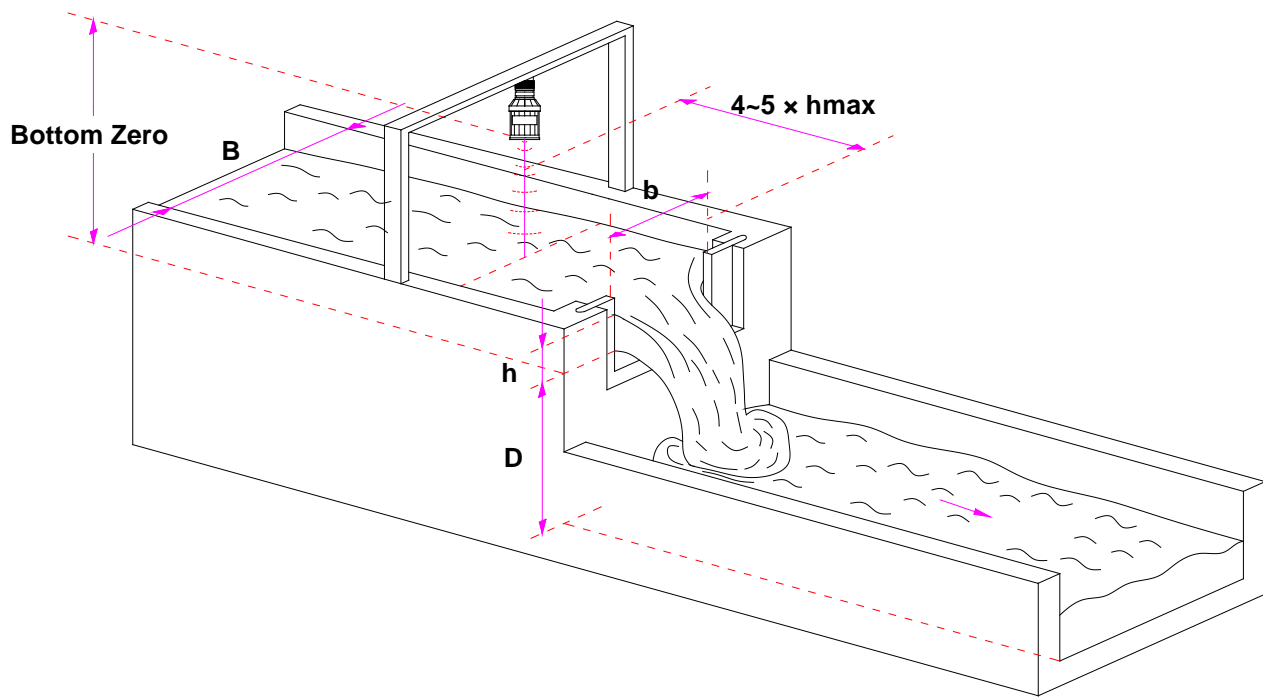

<Fig. B-2 > Aerial View of Rectangular Weir

Thank you for purchasing the FLOW HUNTER II.

Please call if you have any questions or need technical support.



ECHO Process Instrumentation, Inc.

Mail to: PO Box 800, Shalimar, FL 32579 USA

Ship to: 70 6th Ave, Shalimar, FL 32579 USA

Phone: 850-609-1300 - Fax: 850-651-4777

Email: info@echopi.com - Website: www.echopi.com